

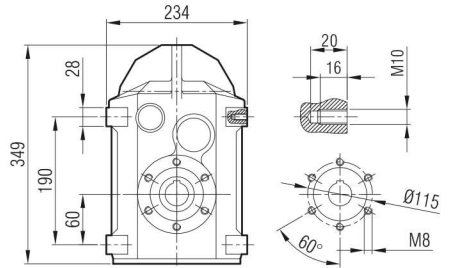

YPM 72
YPM 73

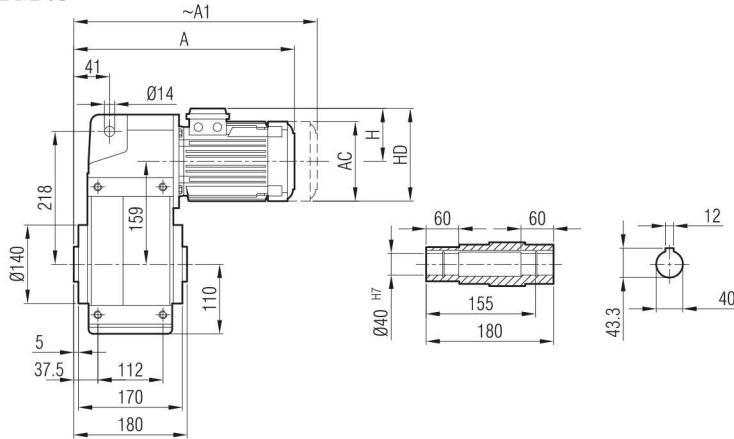

	71	80	90 S	90 L	100	112	132 S	132 M
A	372	401	431	456	495	515	562	600
A ₁	423	470	497	522	573	598	662	700
H	111	118	126	126	134	145	168	168
HD	182	198	216	216	234	257	300	300
AC	138	156	176	176	194	218	257	257

YP 72
YP 73

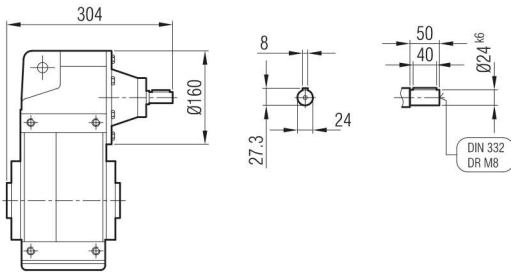

"A₁" Ölçüsü Frenli Motorlar içindir.
Dimension "A₁" is for motors with brake.
Le dimensions "A₁" correspondent aux moteurs équipés de freins.

YPPM 72
YPPM 73

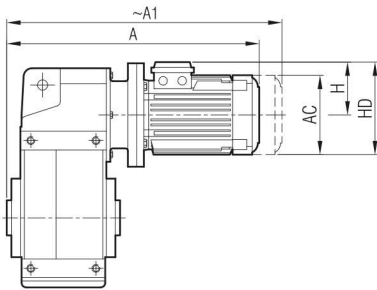

	63/B5	71/B5	80/B5	90 S/B5	90 L/B5	100/B5	112/B5	132 S/B5	132 M/B5
A	393	429	455	470	495	540	560	620	658
A ₁	449	480	524	536	561	618	643	720	758
H	97	111	118	126	126	134	145	168	168
HD	160	182	198	216	216	234	257	300	300
AC	121	138	156	176	176	194	218	257	257

"A₁" Ölçüsü Frenli Motorlar içindir.
Dimension "A₁" is for motors with brake.
Le dimensions "A₁" correspondent aux moteurs équipés de freins.

YPP 72
YPP 73

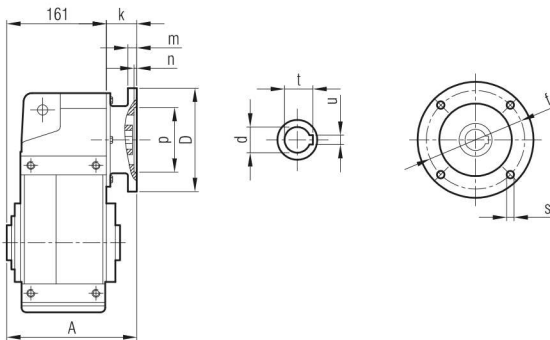

	A	Øp	Øf	ØD	s	k	m	n	Ød	t	u
63/B5	197	95	115	140	M8	35.5	8	4	11	12.8	4
71/B5	206	110	130	160	M8	45	9	4	14	16.3	5
80/B5	211	130	165	200	M10	50	12	5	19	21.8	6
90/B5	211	130	165	200	M10	50	12	5	24	27.3	8
100/B5	224	180	215	250	M12	63	14	5	28	31.3	8
112/B5	224	180	215	250	M12	63	14	5	28	31.3	8
132/B5	240	230	265	300	M12	79	17	5	38	41.3	10