

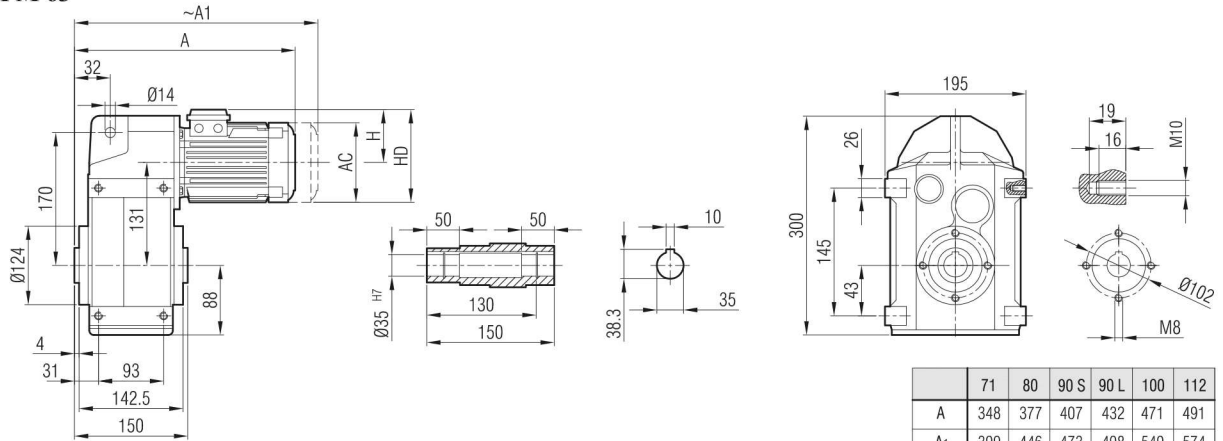

YPM 62
YPM 63



	71	80	90 S	90 L	100	112
A	348	377	407	432	471	491
A ₁	399	446	473	498	549	574
H	111	118	126	126	134	145
HD	182	198	216	216	234	257
AC	138	156	176	176	194	218

YP 62
YP 63

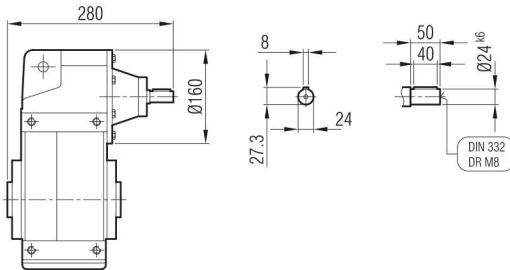

"A₁" Ölçüsü Frenli Motorlar içindir.
Dimension "A₁" is for motors with brake.
Le dimensions "A₁" correspondent aux moteurs équipés de freins.

YPPM 62
YPPM 63

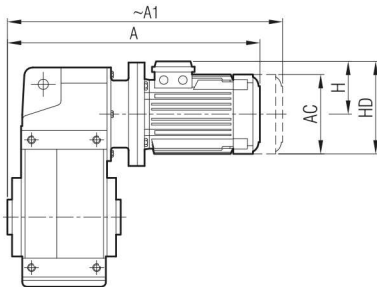

	63/B5	71/B5	80/B5	90 S/B5	90 L/B5	100/B5	112/B5
A	369	405	431	446	471	516	536
A ₁	425	456	500	512	537	594	619
H	97	111	118	126	126	134	145
HD	160	182	198	216	216	234	257
AC	121	138	156	176	176	194	218

"A₁" Ölçüsü Frenli Motorlar içindir.
Dimension "A₁" is for motors with brake.
Le dimensions "A₁" correspondent aux moteurs équipés de freins.

YPP 62
YPP 63

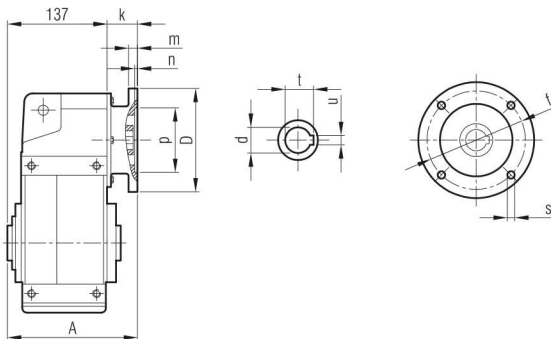

	A	Øp	Øf	ØD	s	k	m	n	Ød	t	u
63/B5	173	95	115	140	M8	35.5	8	4	11	12.8	4
71/B5	182	110	130	160	M8	45	9	4	14	16.3	5
80/B5	187	130	165	200	M10	50	12	5	19	21.8	6
90/B5	187	130	165	200	M10	50	12	5	24	27.3	8
100/B5	200	180	215	250	M12	63	14	5	28	31.3	8
112/B5	200	180	215	250	M12	63	14	5	28	31.3	8