

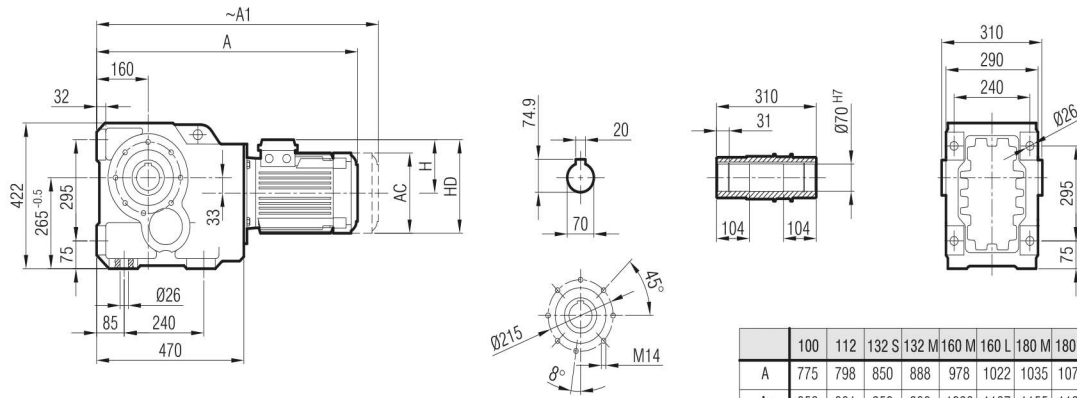

İRKM 103



	100	112	132 S	132 M	160 M	160 L	180 M	180 L	200
A	775	798	850	888	978	1022	1035	1073	1114
A ₁	853	881	950	988	1093	1137	1155	1193	1234
H	141	149	182	182	225	225	248	248	275
HD	241	261	314	314	385	385	428	428	425
AC	217	232	279	279	325	325	370	370	415

İRK 103

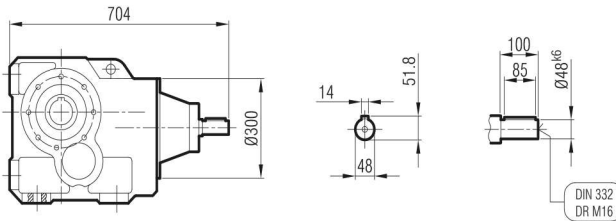

"A₁" Ölçüsü Frenli Motorlar içindir.
Dimension "A₁" is for motors with brake
Maß "A₁" ist für Motoren mit Bremse

İRKPM 103

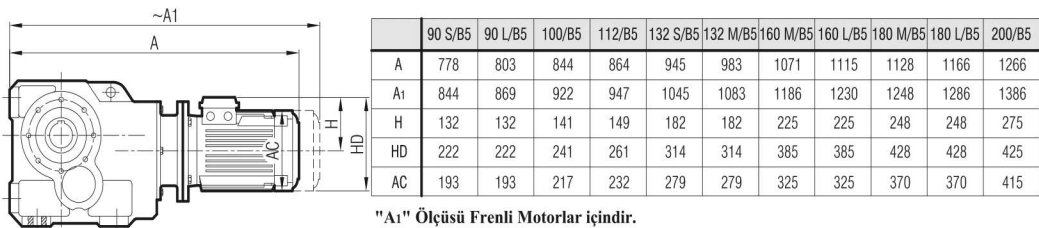

	90 S/B5	90 L/B5	100/B5	112/B5	132 S/B5	132 M/B5	160 M/B5	160 L/B5	180 M/B5	180 L/B5	200/B5
A	778	803	844	864	945	983	1071	1115	1128	1166	1266
A ₁	844	869	922	947	1045	1083	1186	1230	1248	1286	1386
H	132	132	141	149	182	182	225	225	248	248	275
HD	222	222	241	261	314	314	385	385	428	428	425
AC	193	193	217	232	279	279	325	325	370	370	415

"A₁" Ölçüsü Frenli Motorlar içindir.
Dimension "A₁" is for motors with brake
Maß "A₁" ist für Motoren mit Bremse

İRKP 103

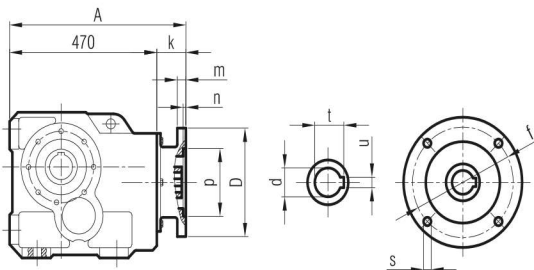

	A	Øp	Øf	ØD	s	k	m	n	Ød	t	u
90/B5	519	130	165	200	M10	49	12	5	24	27.3	8
100/B5	528	180	215	250	M12	58	14	5	28	31.3	8
112/B5	528	180	215	250	M12	58	14	5	28	31.3	8
132/B5	565	230	265	300	M12	95	17	6	38	41.3	10
160/B5	581	250	300	350	M14	111	18	6.5	42	45.3	12
180/B5	581	250	300	350	M14	111	18	6.5	48	51.8	14
200/B5	629	300	350	400	M16	159	20	6.5	55	59.3	16