

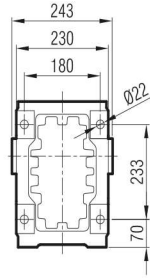

İRKM 93

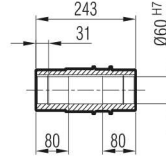
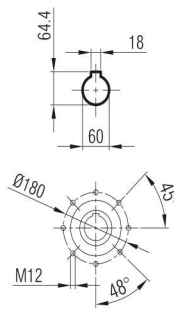
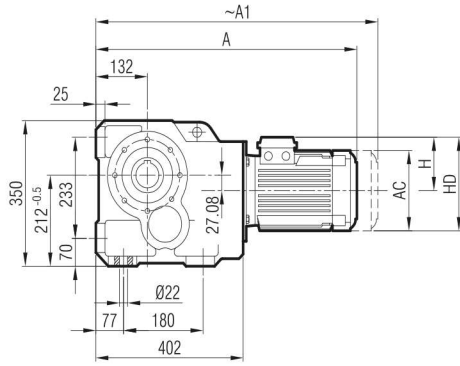

	80	90 S	90 L	100	112	132 S	132 M	160 M	160 L	180 M	180 L
A	624	652	677	717	739	801	839	941	985	998	1036
A ₁	693	718	743	795	822	901	939	1056	1100	1118	1156
H	118	132	132	141	149	182	182	225	225	248	248
HD	198	222	222	241	261	314	314	385	385	428	428
AC	158	193	193	217	232	279	279	325	325	370	370

İRK 93

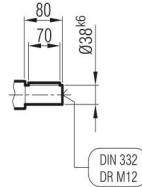
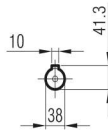
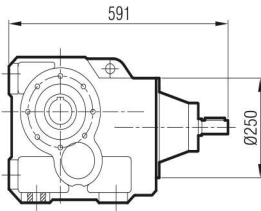

"A₁" Ölçüsü Frenli Motorlar içindir.
Dimension "A₁" is for motors with brake
Maß "A₁" ist für Motoren mit Bremse

İRKPM 93

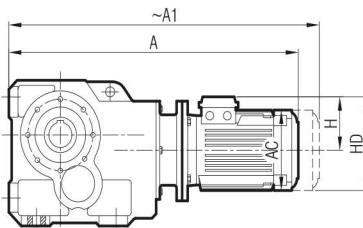

	80/B5	90 S/B5	90 L/B5	100/B5	112/B5	132 S/B5	132 M/B5	160 M/B5	160 L/B5	180 M/B5	180 L/B5
A	712	727	752	792	812	877	915	1003	1047	1060	1098
A ₁	781	793	818	870	895	977	1015	1118	1162	1180	1218
H	118	132	132	141	149	182	182	225	225	248	248
HD	198	222	222	241	261	314	314	385	385	428	428
AC	158	193	193	217	232	279	279	325	325	370	370

"A₁" Ölçüsü Frenli Motorlar içindir.
Dimension "A₁" is for motors with brake
Maß "A₁" ist für Motoren mit Bremse

İRKP 93

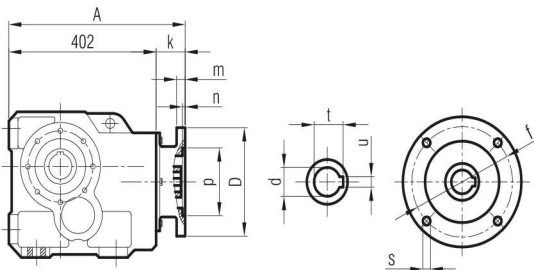

	A	Øp	Øf	ØD	s	k	m	n	Ød	t	u
80/B5	468	130	165	200	M10	67	12	5	19	21.8	6
90/B5	468	130	165	200	M10	67	12	5	24	27.3	8
100/B5	476	180	215	250	M12	74	14	5	28	31.3	8
112/B5	476	180	215	250	M12	74	14	5	28	31.3	8
132/B5	497	230	265	300	M12	95	17	6	38	41.3	10
160/B5	513	250	300	350	M14	111	18	6.5	42	45.3	12
180/B5	513	250	300	350	M14	111	18	6.5	48	51.8	14