

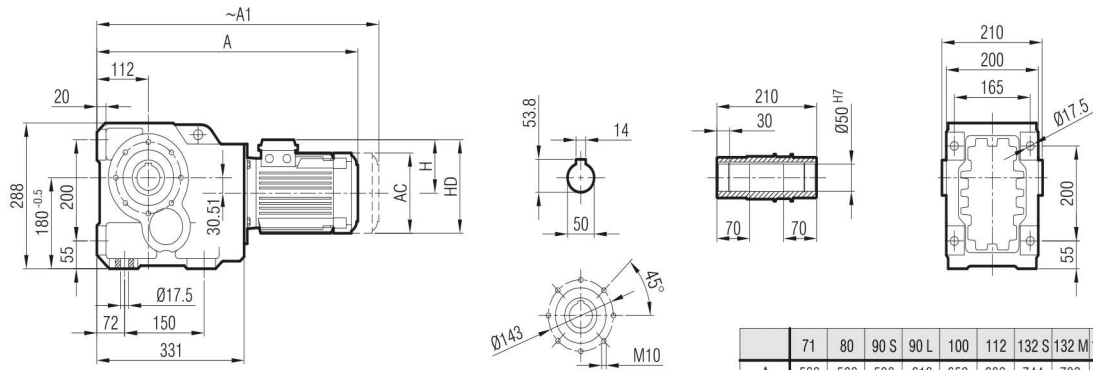

İRKM 83



	71	80	90 S	90 L	100	112	132 S	132 M	160 M
A	533	563	593	618	659	682	744	782	860
A ₁	584	632	659	684	737	765	844	882	975
H	111	118	132	132	141	149	182	182	225
HD	182	198	222	222	241	261	314	314	385
AC	138	158	193	193	217	232	279	279	325

"A₁" Ölçüsü Frenli Motorlar içindir.
Dimension "A₁" is for motors with brake
Maß "A₁" ist für Motoren mit Bremse

İRK 83

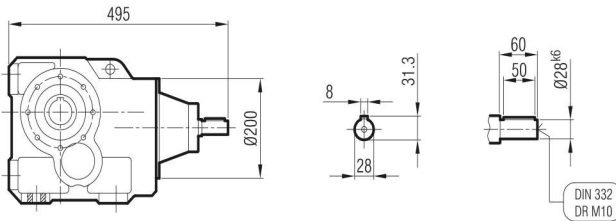

İRKPM 83

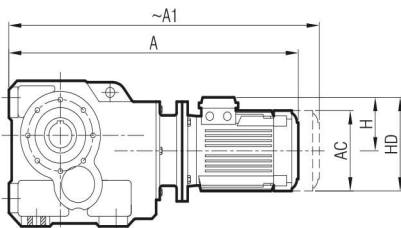

	71/B5	80/B5	90 S/B5	90 L/B5	100/B5	112/B5	132 S/B5	132 M/B5	160 M/B5
A	609	642	657	682	719	739	807	845	932
A ₁	660	711	723	748	797	822	907	945	1047
H	111	118	132	132	141	149	182	182	225
HD	182	198	222	222	241	261	314	314	385
AC	138	158	193	193	217	232	279	279	325

"A₁" Ölçüsü Frenli Motorlar içindir.
Dimension "A₁" is for motors with brake
Maß "A₁" ist für Motoren mit Bremse

İRKP 83

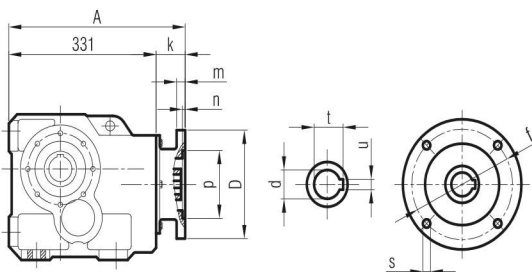

	A	Øp	Øf	ØD	s	k	m	n	Ød	t	u
71/B5	386	110	130	160	M8	55	10	4	14	16.3	5
80/B5	398	130	165	200	M10	67	12	5	19	21.8	6
90/B5	398	130	165	200	M10	67	12	5	24	27.3	8
100/B5	403	180	215	250	M12	71.5	14	5	28	31.3	8
112/B5	403	180	215	250	M12	71.5	14	5	28	31.3	8
132/B5	427	230	265	300	M12	95.5	17	5	38	41.3	10
160/B5	442	250	300	350	M14	111	18	6.5	42	45.3	12