

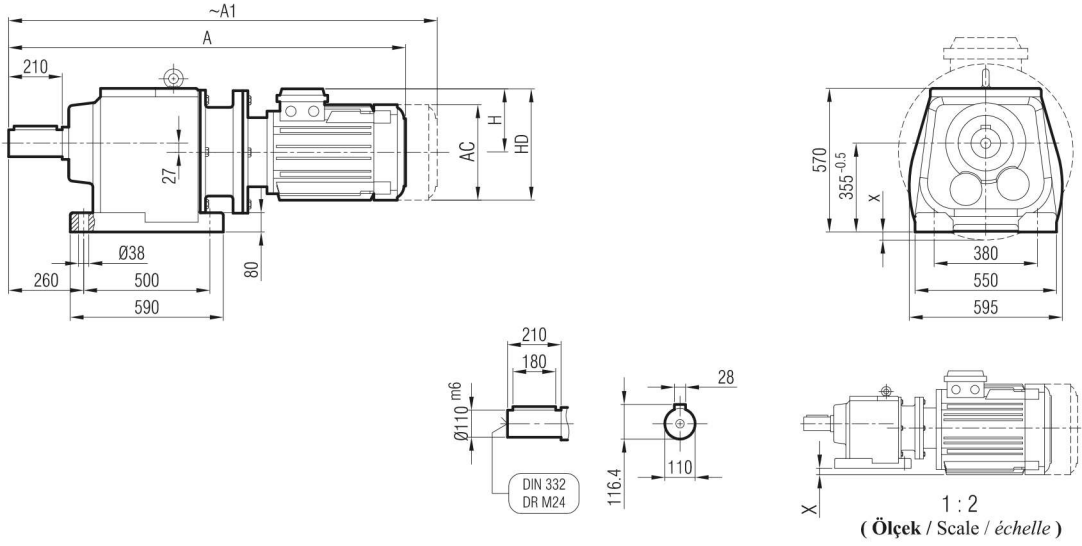

İRAPM 142
İRAPM 143

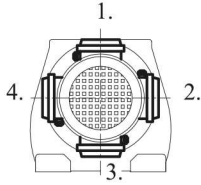

Klemens Pozisyonları
Terminal Box Positions
Klemmenkasten Positionen



	132 M/B5	160 M/B5	160 L/B5	180 M/B5	180 L/B5	200/B5	225 S/B5	225 M/B5	250/B5	280 S/B5	280 M/B5
A	1213	1310	1354	1367	1405	1525	1552	1577	1653	1715	1715
A1	1313	1425	1469	1487	1525	1645	1672	1697	1773	1835	1915
H	168	220	220	241	241	241	285	285	322	350	350
HD	300	380	380	421	421	421	510	510	572	630	630
AC	257	310	310	348	348	348	434	434	480	544	544
X	-	-	-	-	-	-	-	-	-	-	-

"A1" Ölçüsü Frenli Motorlar içindir.
Dimension "A1" is for motors with brake
Le dimensions "A1" correspondent aux moteurs équipés de freins.

İRAP 142
İRAP 143

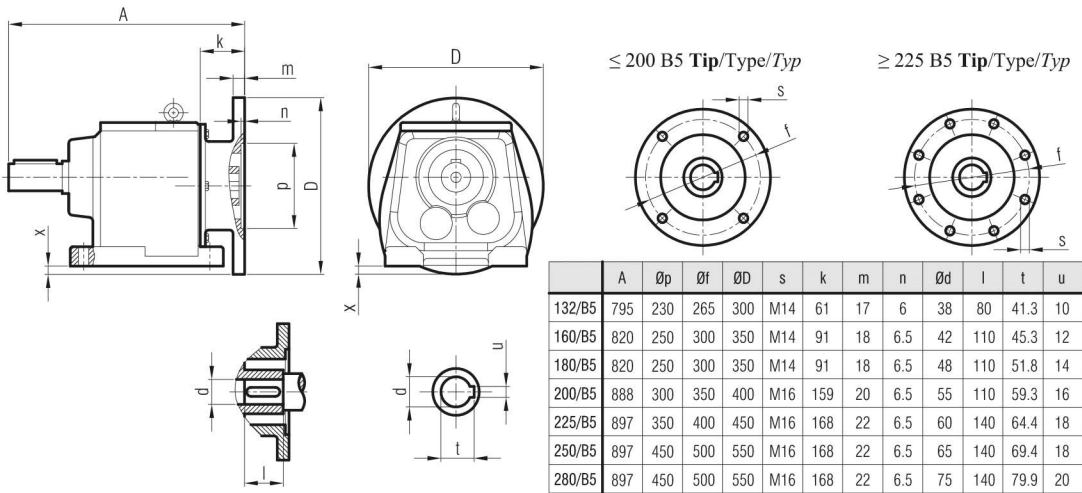

	A	Øp	Øf	ØD	s	k	m	n	Ød	l	t	u	x
132/B5	795	230	265	300	M14	61	17	6	38	80	41.3	10	-
160/B5	820	250	300	350	M14	91	18	6.5	42	110	45.3	12	-
180/B5	820	250	300	350	M14	91	18	6.5	48	110	51.8	14	-
200/B5	888	300	350	400	M16	159	20	6.5	55	110	59.3	16	-
225/B5	897	350	400	450	M16	168	22	6.5	60	140	64.4	18	-
250/B5	897	450	500	550	M16	168	22	6.5	65	140	69.4	18	-
280/B5	897	450	500	550	M16	168	22	6.5	75	140	79.9	20	-