

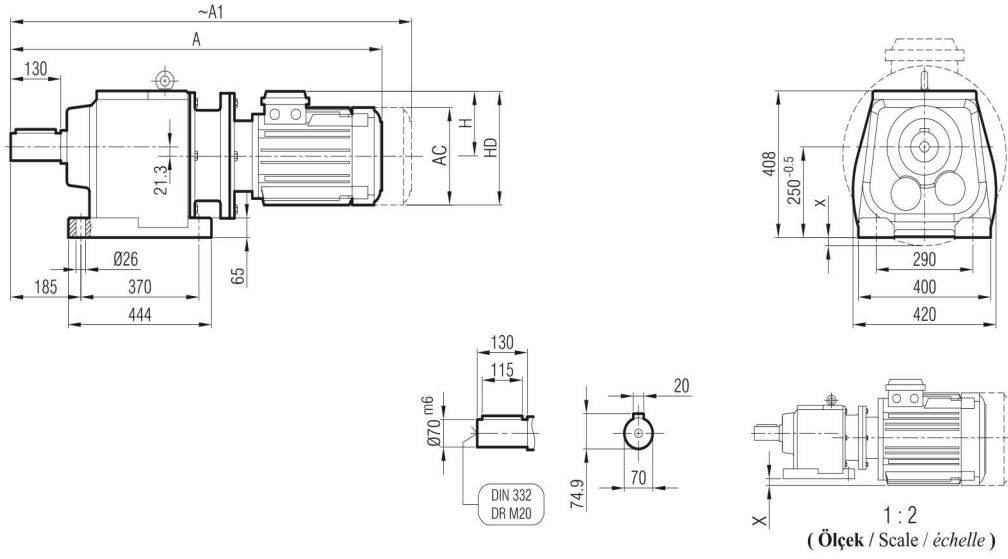

İRAPM 102
İRAPM 103

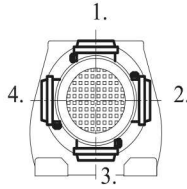

Klemens Pozisyonları
Terminal Box Positions
Klemmenkasten Positionen



	100/B5	112/B5	132 S/B5	132 M/B5	160 M/B5	160 L/B5	180 M/B5	180 L/B5	200/B5	225 S/B5	225 M/B5
A	903	923	994	1032	1111	1155	1168	1206	1326	1351	1376
A ₁	981	1006	1094	1132	1226	1270	1288	1326	1446	1471	1496
H	134	145	168	168	220	220	241	241	241	285	285
HD	234	257	300	300	380	380	421	421	421	510	510
AC	194	218	257	257	310	310	348	348	348	434	434
X	-	-	-	-	-	-	-	-	-	-	-

"A₁" Ölçüsü Frenli Motorlar içindir.
Dimension "A₁" is for motors with brake
Le dimensions "A₁" correspond aux moteurs équipés de freins.

İRAP 102
İRAP 103

