

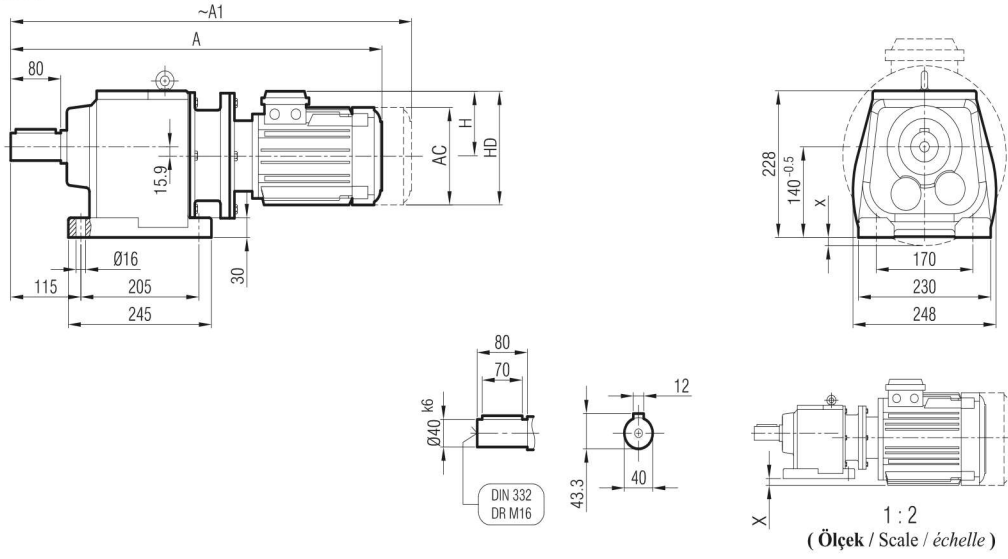

İRAPM 72
İRAPM 73

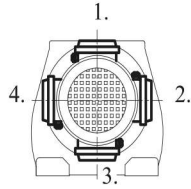

Klemens Pozisyonları
Terminal Box Positions
Klemmenkasten Positionen



	71/B5	80/B5	90 S/B5	90 L/B5	100/B5	112/B5	132 S/B5	132 M/B5	160 M/B5
A	581	614	629	654	691	711	779	817	904
A1	632	683	695	720	769	794	879	917	1019
H	111	118	126	126	134	145	168	168	220
HD	182	198	216	216	234	257	300	300	380
AC	138	156	176	176	194	218	257	257	310
X	-	-	-	-	-	-	5	5	31

"A1" Ölçüsü Frenli Motorlar içindir.

Dimension "A1" is for motors with brake

Le dimensions "A1" correspond aux moteurs équipés de freins.

İRAP 72
İRAP 73

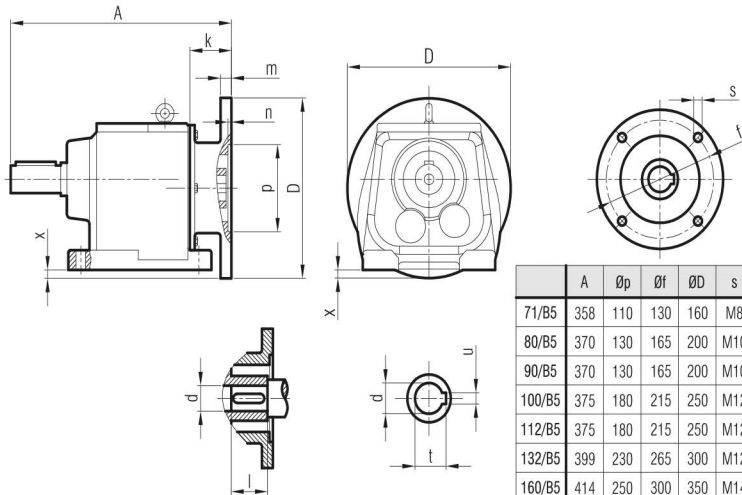

	A	Øp	Øf	ØD	s	k	m	n	Ød	l	t	u	x
71/B5	358	110	130	160	M8	55	10	4	14	30	16.3	5	-
80/B5	370	130	165	200	M10	67	12	5	19	40	21.8	6	-
90/B5	370	130	165	200	M10	67	12	5	24	50	27.3	8	-
100/B5	375	180	215	250	M12	72	14	5	28	60	31.3	8	1
112/B5	375	180	215	250	M12	72	14	5	28	60	31.3	8	1
132/B5	399	230	265	300	M12	96	17	5	38	80	41.3	10	26
160/B5	414	250	300	350	M14	111	18	6.5	42	109	41.3	10	51