

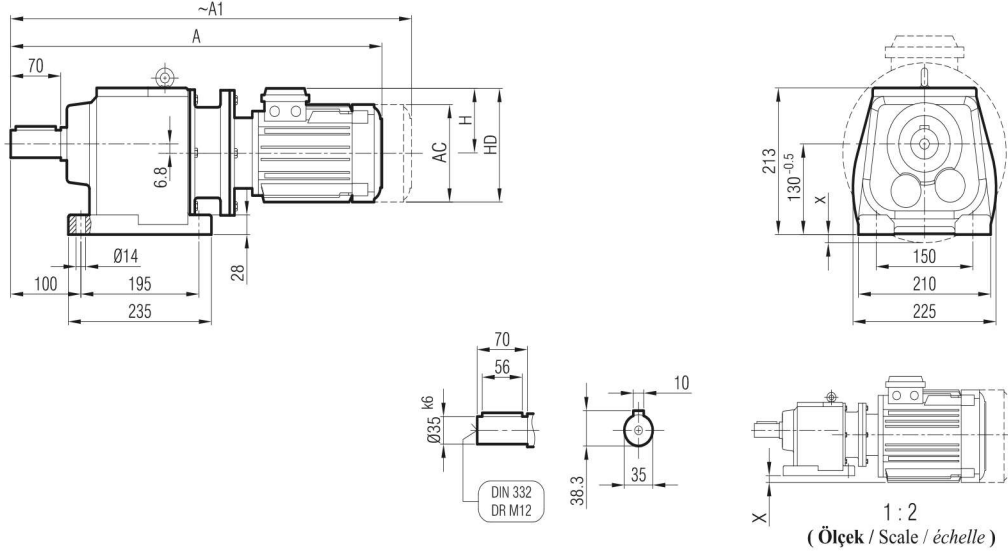

İRAPM 721  
İRAPM 731

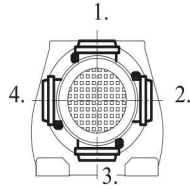

**Klemens Pozisyonları**  
Terminal Box Positions  
Klemmenkasten Positionen



	71/B5	80/B5	90 S/B5	90 L/B5	100/B5	112/B5	132 S/B5	132 M/B5
A	553	586	601	626	663	683	751	789
A <sub>1</sub>	604	655	667	692	741	766	851	889
H	111	118	126	126	134	145	168	168
HD	182	198	216	216	234	257	300	300
AC	138	156	176	176	194	218	257	257
x	-	-	-	-	-	-	6	6

"A<sub>1</sub>" Ölçüsü Frenli Motorlar içindir.  
Dimension "A<sub>1</sub>" is for motors with brake  
Le dimensions "A<sub>1</sub>" correspondent aux moteurs équipés de freins.

İRAP 721  
İRAP 731

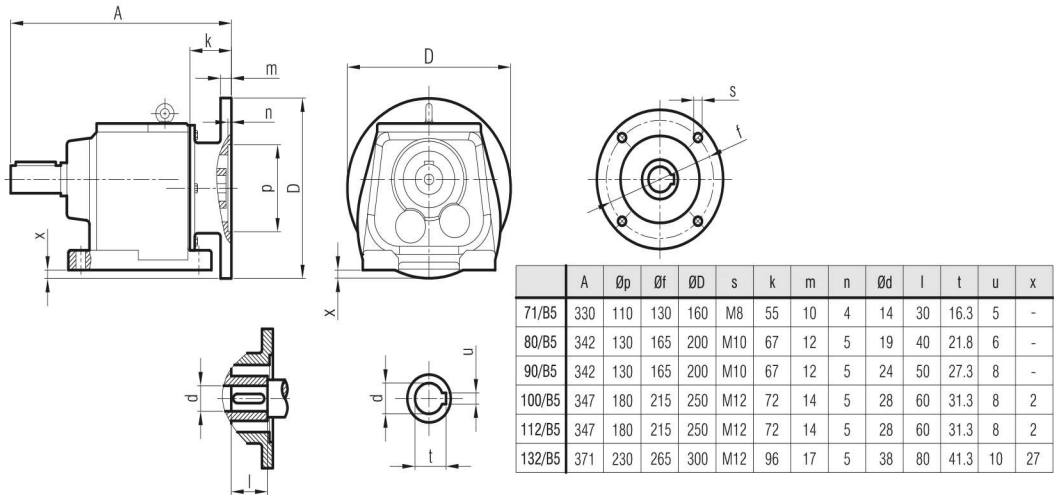

	A	Øp	Øf	ØD	s	k	m	n	Ød	l	t	u	x
71/B5	330	110	130	160	M8	55	10	4	14	30	16.3	5	-
80/B5	342	130	165	200	M10	67	12	5	19	40	21.8	6	-
90/B5	342	130	165	200	M10	67	12	5	24	50	27.3	8	-
100/B5	347	180	215	250	M12	72	14	5	28	60	31.3	8	2
112/B5	347	180	215	250	M12	72	14	5	28	60	31.3	8	2
132/B5	371	230	265	300	M12	96	17	5	38	80	41.3	10	27