

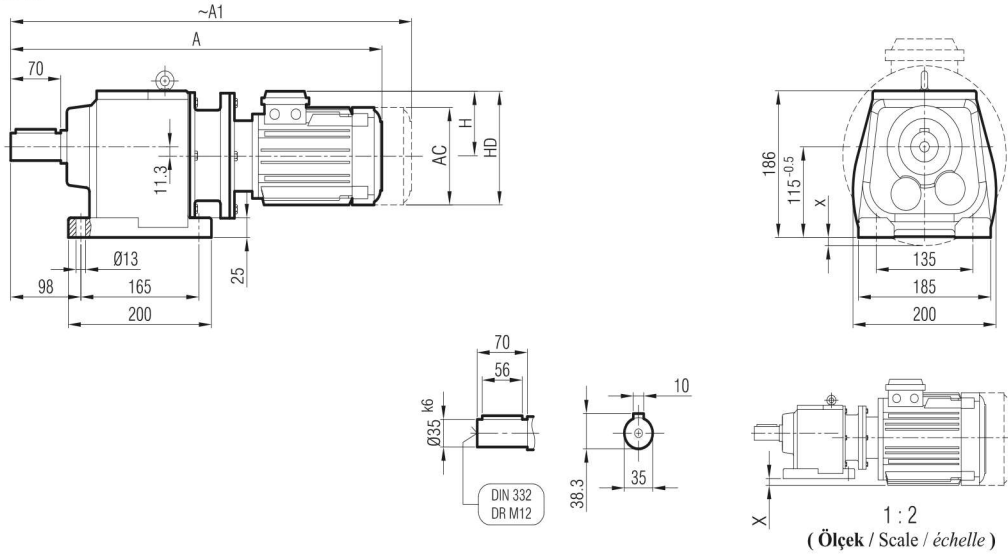

İRAPM 62
İRAPM 63

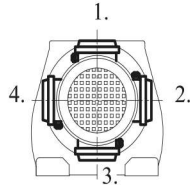

Klemens Pozisyonları
Terminal Box Positions
Klemmenkasten Positionen



	63/B5	71/B5	80/B5	90 S/B5	90 L/B5	100/B5	112/B5	132 S/B5
A	483	518	544	560	585	630	650	710
A ₁	539	569	613	626	651	708	733	810
H	97	111	118	126	126	134	145	168
HD	160	182	198	216	216	234	257	300
AC	121	138	156	176	176	194	218	257
x	-	-	-	-	-	-	5	25

"A₁" Ölçüsü Frenli Motorlar içindir.
Dimension "A₁" is for motors with brake
Le dimensions "A₁" correspondent aux moteurs équipés de freins.

İRAP 62
İRAP 63

