

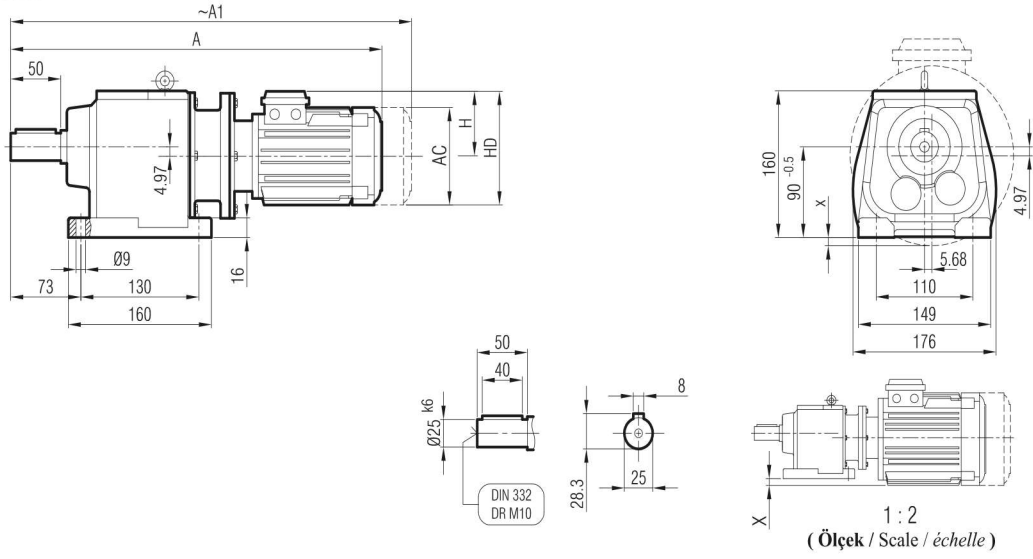

İRAPM 52
İRAPM 53

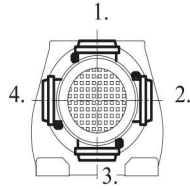

Klemens Pozisyonları
Terminal Box Positions
Klemmenkasten Positionen



	63/B5	71/B5	80/B5	90 S/B5	90 L/B5	100/B5
A	430	465	488	503	528	574
A ₁	486	516	557	569	594	652
H	97	111	118	126	126	134
HD	160	182	198	216	216	234
AC	121	138	156	176	176	194
x	-	-	-	3	3	12

"A₁" Ölçüsü Frenli Motorlar içindir.
Dimension "A₁" is for motors with brake
Le dimensions "A₁" correspond aux moteurs
équipés de freins.

İRAP 52
İRAP 53

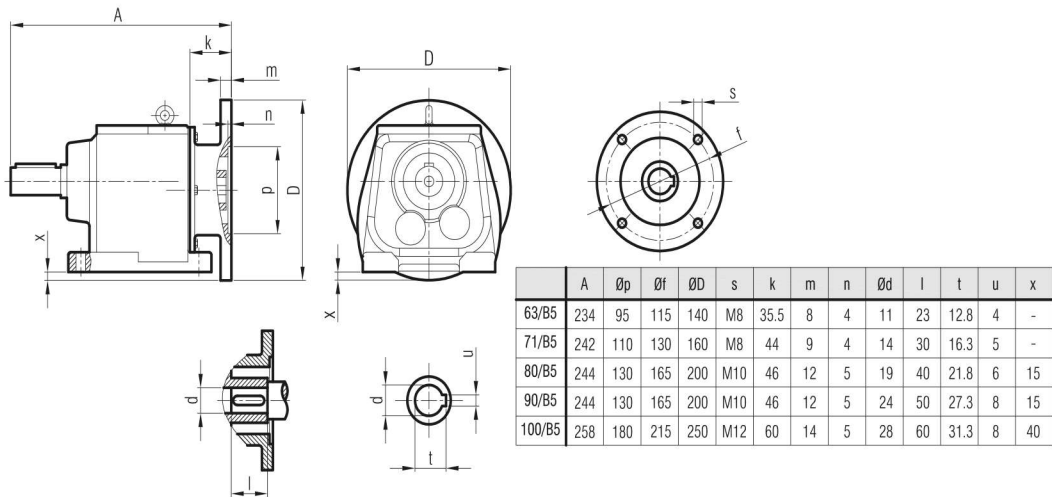

	A	Øp	Øf	ØD	s	k	m	n	Ød	l	t	u	x
63/B5	234	95	115	140	M8	35.5	8	4	11	23	12.8	4	-
71/B5	242	110	130	160	M8	44	9	4	14	30	16.3	5	-
80/B5	244	130	165	200	M10	46	12	5	19	40	21.8	6	15
90/B5	244	130	165	200	M10	46	12	5	24	50	27.3	8	15
100/B5	258	180	215	250	M12	60	14	5	28	60	31.3	8	40