

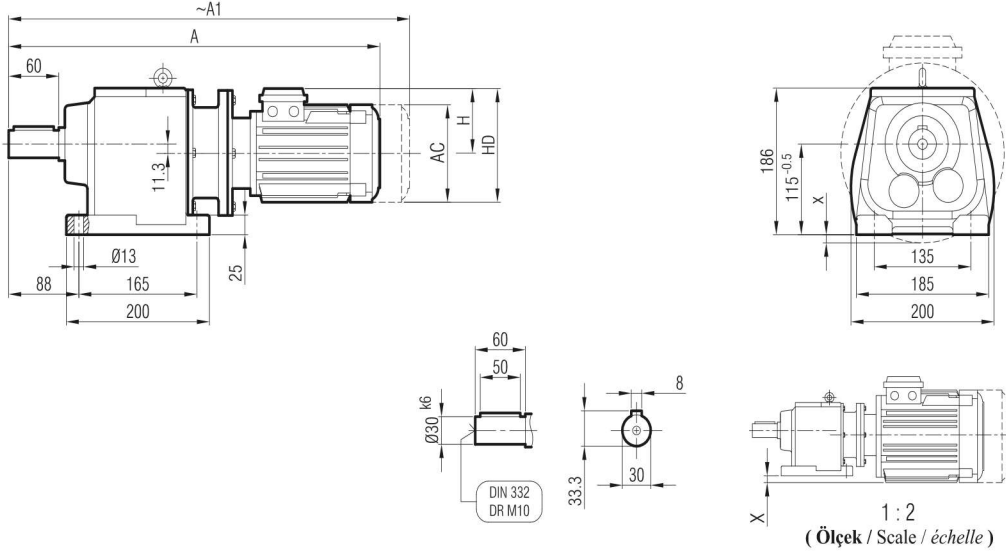

İRAPM 621
İRAPM 631

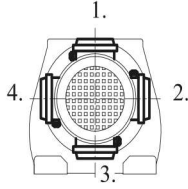

Klemens Pozisyonları
Terminal Box Positions
Klemmenkasten Positionen



	63/B5	71/B5	80/B5	90 S/B5	90 L/B5	100/B5	112/B5	132 S/B5
A	473	508	534	550	575	620	640	700
A ₁	529	559	603	616	641	698	723	800
H	97	111	118	126	126	134	145	168
HD	160	182	198	216	216	234	257	300
AC	121	138	156	176	176	194	218	257
x	-	-	-	-	-	-	5	25

"A₁" Ölçüsü Frenli Motorlar içindir.

Dimension "A₁" is for motors with brake

Le dimensions "A₁" correspond aux moteurs équipés de freins.

İRAP 621
İRAP 631

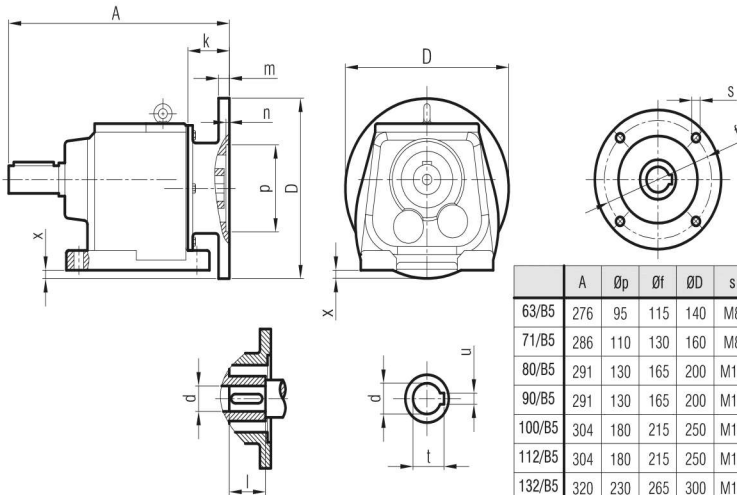

	A	Øp	Øf	ØD	s	k	m	n	Ød	l	t	u	x
63/B5	276	95	115	140	M8	35.5	8	4	11	23	12.8	4	-
71/B5	286	110	130	160	M8	45	9	4	14	30	16.3	5	-
80/B5	291	130	165	200	M10	50	12	5	19	40	21.8	6	-
90/B5	291	130	165	200	M10	50	12	5	24	50	27.3	8	-
100/B5	304	180	215	250	M12	63	14	5	28	60	31.3	8	22
112/B5	304	180	215	250	M12	63	14	5	28	60	31.3	8	22
132/B5	320	230	265	300	M12	79	17	6	38	80	41.3	10	47