

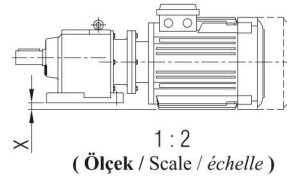

İRAPM 42  
İRAPM 43

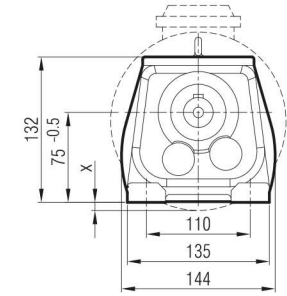

**Klemens Pozisyonları**  
Terminal Box Positions  
Klemmenkasten Positionen

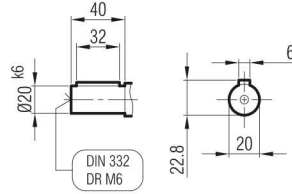
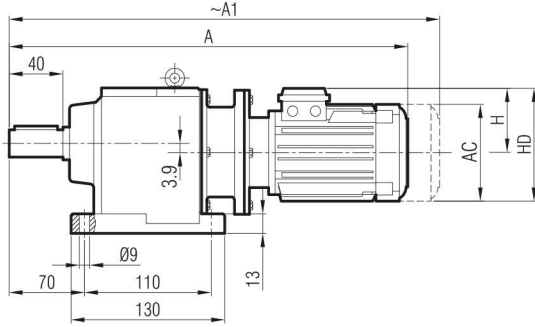
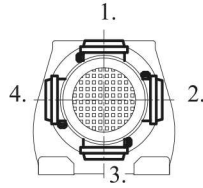

	63/B5	71/B5	80/B5	90 S/B5	90 L/B5
A	397	432	455	470	495
A <sub>1</sub>	453	483	524	536	561
H	97	111	118	126	126
HD	160	182	198	216	216
AC	121	138	156	176	176
x	-	-	7	17	17

"A<sub>1</sub>" Ölçüsü Frenli Motorlar içindir.  
Dimension "A<sub>1</sub>" is for motors with brake  
Le dimensions "A<sub>1</sub>" correspondent aux moteurs équipés de freins.

İRAP 42  
İRAP 43

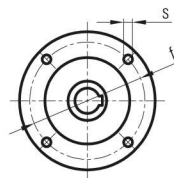
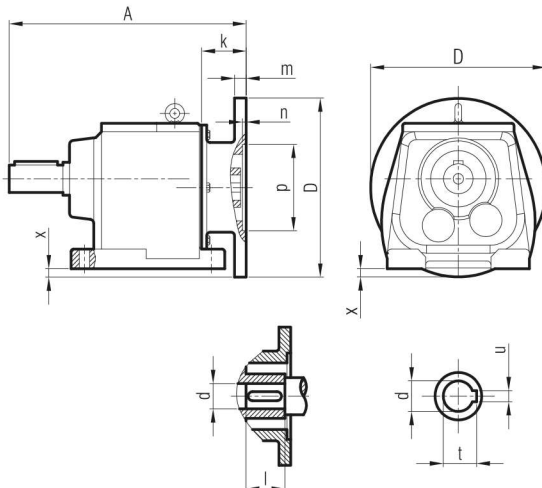

	A	Øp	Øf	ØD	s	k	m	n	Ød	l	t	u	x
63/B5	201	95	115	140	M8	35.5	8	4	11	23	12.8	4	-
71/B5	209	110	130	160	M8	44	9	4	14	30	16.3	5	-
80/B5	211	130	165	200	M10	46	12	5	19	40	21.8	6	29
90/B5	211	130	165	200	M10	46	12	5	24	50	27.3	8	29