

## MD 90 L 2

# GAMAK

شركة الأندلس التجارية  
Al Andalos Trading Co

1-Phase 230 V 50 Hz

Duty Type : S1  
Degree of protection : IP 55 ( TEFC )  
Insulation class : F ( 155 °C )  
Temp rise : Class B ( 80K )  
Mounting Design : B3

### ELECTRICAL DESIGN

Rated output (kW) : 2.2  
Speed (rpm) : 2800  
Rated current (A) : 13.5  
Torque – Mn (Nm) : 7.5  
Permanent Capacitor 400V (μF) : 50  
Cos φ : 0.95  
Efficiency % : 75.0  
Moment of inertia J (kgm)<sup>2</sup> : 0.00141

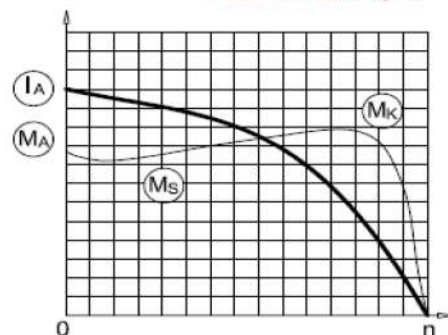

Locked rotor Current – Ia (A) : 45.9  
Ia / In : 3.4  
Locked rotor Torque – Ma (Nm) : 3.8  
Ma / Mn : 0.50  
Breakdown Torque – Mk (Nm) : 12.8  
Mk / Mn : 1.7

### MECHANICAL DESIGN

Frame : Aluminium  
End shields : Aluminium  
Cooling fan : Plastic  
Terminal box : Plastic  
Cable gland : Pg 16  
No of cable glands : 1

### Bearing Arrangement

Standard design : 6205 ZZ  
Paint : RAL 7031- Grey  
Approximate weight (kg) : 15.6

	Drive End	Non Drive End
Standard design	6205 ZZ	6205 ZZ

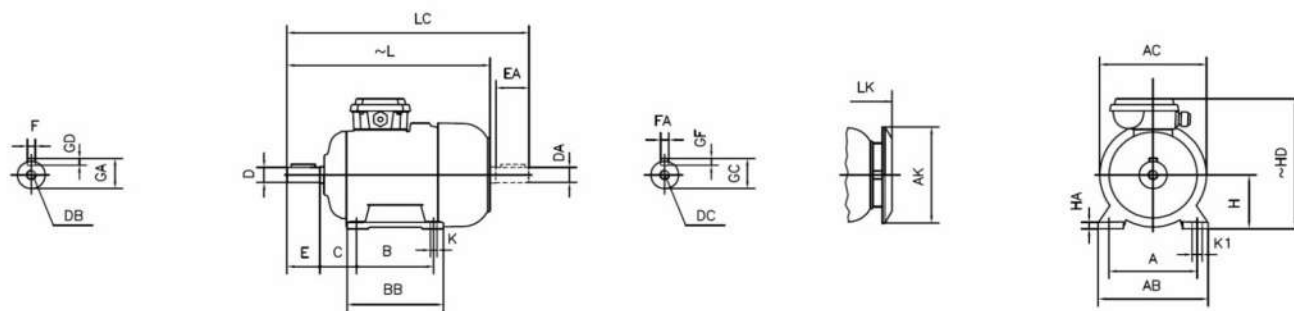

### DIMENSIONS

#### FOOT MOUNTED MOTORS - B3, B6, B7, B8 B15, V5, V6

H	HD	HA	A	AB	AC Ø	AK Ø	K	K1	B	BB	L	LC	LK	C	E	DB	DØ	GA	FXGD
	~										~		-		EA	DC	DAØ	GC	FAXGF
90	23	12	140	180	176	150	10	15	125	155	333	388	363	56	50	M8	24	27	8X7

contact:

Mob:00201022621584/00201092425789

Email:info@andalos-trading.com

website:www.andalos-trading.com

Egypt-Giza-of October City

Lelat Alqader-Almaged Center