

MD 90 S 2

GAMAK

شركة الأندلس التجارية
Al Andalos Trading Co

1-Phase 230 V 50 Hz

- Duty Type : S1
- Degree of protection : IP 55 (TEFC)
- Insulation class : F (155 °C)
- Temp rise : Class B (80K)
- Mounting Design : B3

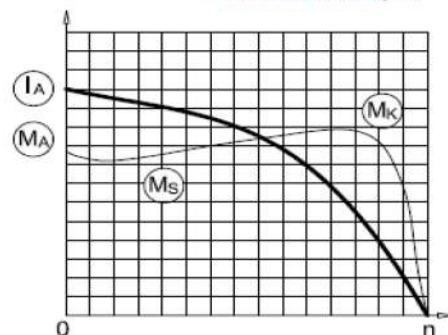

ELECTRICAL DESIGN

- Rated output (kW) : 1.5
- Speed (rpm) : 2820
- Rated current (A) : 9.8
- Torque – Mn (Nm) : 5.08
- Permanent Capacitor 400V (µF) : 40
- Cos φ : 0.91
- Efficiency % : 73.0
- Moment of inertia J (kgm)² : 0.00113
- Locked rotor Current – Ia (A) : 41.16
- Ia / In : 4.2
- Locked rotor Torque – Ma (Nm) : 3.0
- Ma / Mn : 0.60
- Breakdown Torque – Mk (Nm) : 10.2
- Mk / Mn : 2.0

MECHANICAL DESIGN

- Frame : Aluminium
- End shields : Aluminium
- Cooling fan : Plastic
- Terminal box : Plastic
- Cable gland : Pg 16
- No of cable glands : 1

Bearing Arrangement

- Standard design : 6205 ZZ (Drive End) / 6205 ZZ (Non Drive End)
- Paint : RAL 7031- Grey
- Approximate weight (kg) : 13.3

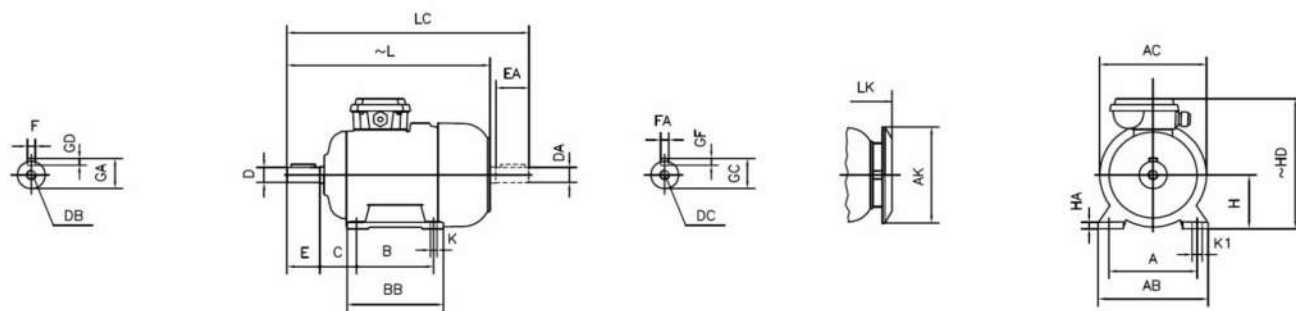

DIMENSIONS

FOOT MOUNTED MOTORS - B3, B6, B7, B8 B15, V5, V6

H	HD	HA	A	AB	AC Ø	AK Ø	K	K1	B	BB	L	LC	LK	C	E	DB	DØ	GA	FXGD
	~										~		-		EA	DC	DAØ	GC	FAXGF
90	23	12	140	180	176	150	10	15	100	130	308	363	338	56	50	M8	24	27	8X7

contact:

Mob:00201022621584/00201092425789

Email:info@andalos-trading.com

website:www.andalos-trading.com

Egypt-Giza-of October City

Lelat Alqader-Almaged Center