

# MD 80 2b

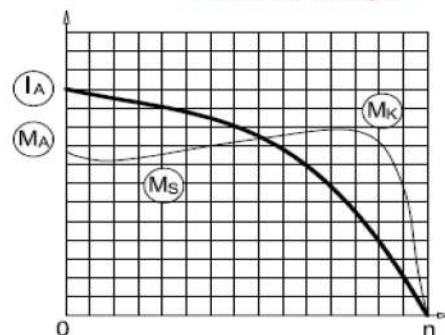

1-Phase 230 V 50 Hz

- Duty Type : S1
- Degree of protection : IP 55 ( TEFC )
- Insulation class : F ( 155 °C )
- Temp rise : Class B ( 80K )
- Mounting Design : B3



## ELECTRICAL DESIGN

- Rated output (kW) : 1.1
- Speed (rpm) : 2770
- Rated current (A) : 7
- Torque – Mn (Nm) : 3.79
- Permanent Capacitor 400V (µF) : 35
- Cos φ : 0.95
- Efficiency % : 72.0
- Moment of inertia J (kgm)<sup>2</sup> : 0,00070
- Locked rotor Current – Ia (A) : 26.6
- Ia / In : 3.8
- Locked rotor Torque – Ma (Nm) : 3.5
- Ma / Mn : 0.93
- Breakdown Torque – Mk (Nm) : 7.6
- Mk / Mn : 2.0

## MECHANICAL DESIGN

- Frame : Aluminium
- End shields : Aluminium
- Cooling fan : Plastic
- Terminal box : Plastic
- Cable gland : Pg 16
- No of cable glands : 1

### Bearing Arrangement

- Standard design
- Paint : RAL 7031- Grey
- Approximate weight (kg) : 10.4

|                 | Drive End | Non Drive End |
|-----------------|-----------|---------------|
| Standard design | 6204 ZZ   | 6204 ZZ       |

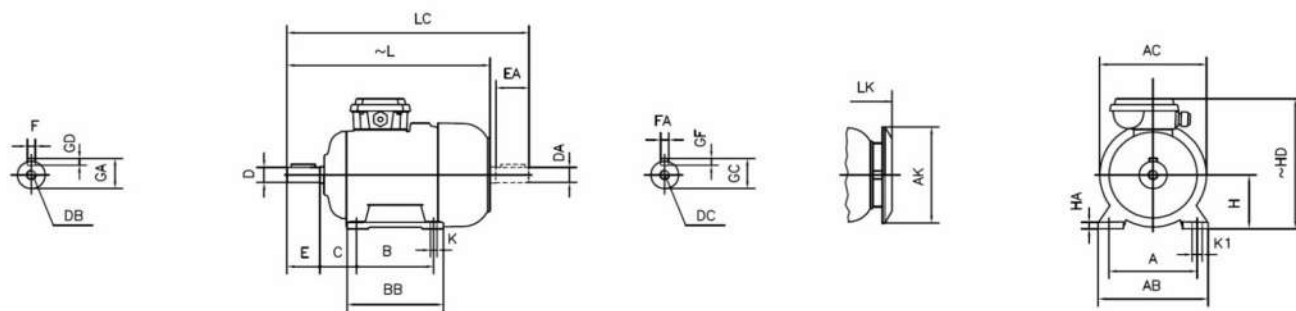

## DIMENSIONS

### FOOT MOUNTED MOTORS - B3, B6, B7, B8 B15, V5, V6

| H  | HD  | HA | A   | AB  | AC Ø | AK Ø | K  | K1 | B   | BB  | L   | LC  | LK  | C  | E  | DB | DØ  | GA   | FXGD  |
|----|-----|----|-----|-----|------|------|----|----|-----|-----|-----|-----|-----|----|----|----|-----|------|-------|
|    | ~   |    |     |     |      |      |    |    |     |     | ~   |     | -   |    | EA | DC | DAØ | GC   | FAXGF |
| 80 | 212 | 10 | 125 | 160 | 156  | 150  | 10 | 15 | 100 | 125 | 278 | 323 | 308 | 50 | 40 | M6 | 19  | 21.5 | 6X6   |

contact:

Mob:00201022621584/00201092425789

Email:info@andalos-trading.com

website:www.andalos-trading.com

Egypt-Giza-of October City

Lelat Alqader-Almaged Center