

MD 71 2b

GAMAK

شركة الأندلس التجارية
Al Andalos Trading Co

1-Phase 230 V 50 Hz

Duty Type : S1
Degree of protection : IP 55 (TEFC)
Insulation class : F (155 °C)
Temp rise : Class B (80K)
Mounting Design : B3

ELECTRICAL DESIGN

Rated output (kW) : 0.55

Speed (rpm) : 2865

Rated current (A) : 3.5

Torque – Mn (Nm) : 1.83

Permanent Capacitor 400V (μF) : 20

Cos φ : 0.98

Efficiency % : 70.0

Moment of inertia J (kgm)² : 0.00035

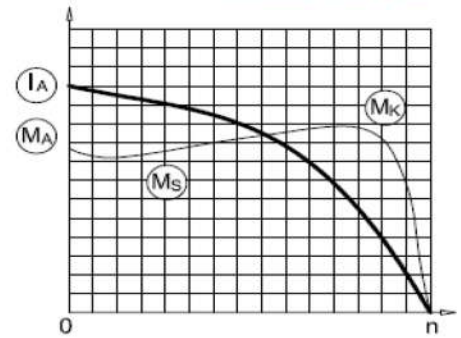

Locked rotor Current – Ia (A) : 13.65

Ia / In : 3.9

Locked rotor Torque – Ma (Nm) : 1.3

Ma / Mn : 0.72

Breakdown Torque – Mk (Nm) : 4.2

Mk / Mn : 2.3

MECHANICAL DESIGN

Frame : Aluminium
End shields : Aluminium
Cooling fan : Plastic
Terminal box : Plastic
Cable gland : Pg 16
No of cable glands : 1

Bearing Arrangement

Standard design

Paint

Approximate weight (kg) : 6.8

Drive End

6202 ZZ

Non Drive End

6202 ZZ

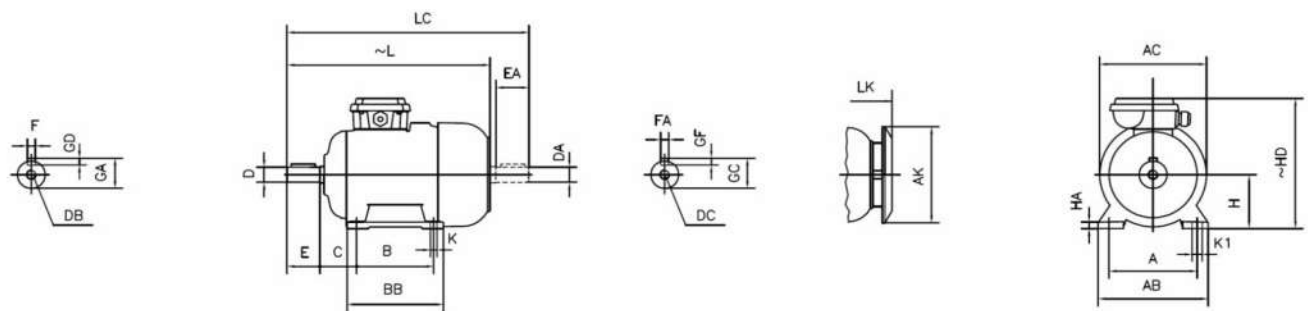

DIMENSIONS

FOOT MOUNTED MOTORS - B3, B6, B7, B8 B15, V5, V6

H	HD	HA	A	AB	AC Ø	AK Ø	K	K1	B	BB	L	LC	LK	C	E	DB	DØ	GA	FXGD
	~										~		~		EA	DC	DAØ	GC	FAXGF
71	196	10	112	140	138	116	7	11	90	108	247	282	277	45	30	M5	14	16	5X5

contact:

Mob:00201022621584/00201092425789

Email:info@andalos-trading.com

website:www.andalos-trading.com

Egypt-Giza-of October City

Lelat Alqader-Almaged Center