

MD 71 2a

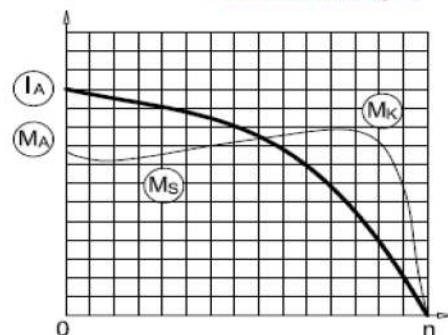

1-Phase 230 V 50 Hz

- Duty Type : S1
- Degree of protection : IP 55 (TEFC)
- Insulation class : F (155 °C)
- Temp rise : Class B (80K)
- Mounting Design : B3



ELECTRICAL DESIGN

- Rated output (kW) : 0.37
- Speed (rpm) : 2885
- Rated current (A) : 2.5
- Torque – Mn (Nm) : 1.22
- Permanent Capacitor 400V (µF) : 15
- Cos φ : 0.96
- Efficiency % : 67.0
- Moment of inertia J (kgm)² : 0.00028

- Locked rotor Current – Ia (A) : 10
- Ia / In : 4
- Locked rotor Torque – Ma (Nm) : 0.8
- Ma / Mn : 0.65
- Breakdown Torque – Mk (Nm) : 2.7
- Mk / Mn : 2.2

MECHANICAL DESIGN

- Frame : Aluminium
- End shields : Aluminium
- Cooling fan : Plastic
- Terminal box : Plastic
- Cable gland : Pg 16
- No of cable glands : 1

Bearing Arrangement

- Standard design : 6202 ZZ
- Paint : RAL 7031- Grey
- Approximate weight (kg) : 5.9

	Drive End	Non Drive End
Standard design	6202 ZZ	6202 ZZ

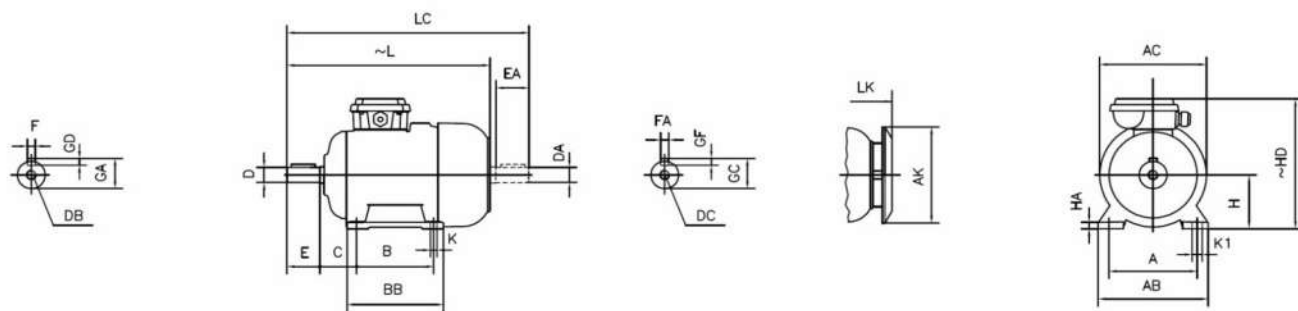

DIMENSIONS

FOOT MOUNTED MOTORS - B3, B6, B7, B8 B15, V5, V6

H	HD	HA	A	AB	AC Ø	AK Ø	K	K1	B	BB	L	LC	LK	C	E	DB	DØ	GA	FXGD
	~										~		~		EA	DC	DAØ	GC	FAXGF
71	196	10	112	140	138	116	7	11	90	108	247	282	277	45	30	M5	14	16	5X5

contact:

Mob:00201022621584/00201092425789

Email:info@andalos-trading.com

website:www.andalos-trading.com

Egypt-Giza-of October City

Lelat Alqader-Almaged Center