

MD 90 S 4

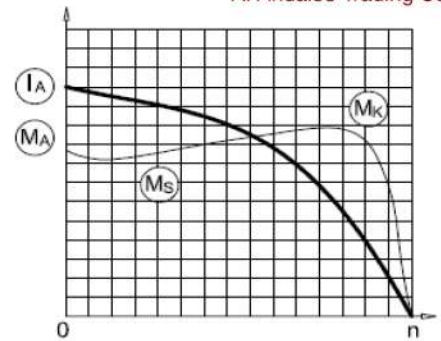

1-Phase 230 V 50 Hz

Duty Type : S1
Degree of protection : IP 55 (TEFC)
Insulation class : F (155 °C)
Temp rise : Class B (80K)
Mounting Design : B3



ELECTRICAL DESIGN

Rated output (kW)	: 1.1	Locked rotor Current – I_a (A)	: 24.85
Speed (rpm)	: 1410		I_a / I_n : 3.5
Rated current (A)	: 7.1	Locked rotor Torque – M_a (Nm)	: 4.69
Torque – M_n (Nm)	: 7.45		M_a / M_n : 0.63
Permanent Capacitor 400V (μF)	: 35	Breakdown Torque – M_k (Nm)	: 14.2
			M_k / M_n : 1.9
Cos φ	: 0.96		
Efficiency %	: 70.0		
Moment of inertia J (kgm^2)	: 0.00209		

MECHANICAL DESIGN

Frame : Aluminium
End shields : Aluminium
Cooling fan : Plastic
Terminal box : Plastic
Cable gland : Pg 16
No of cable glands : 1

Bearing Arrangement

	Drive End	Non Drive End
Standard design	6205 ZZ	6205 ZZ
Paint	: RAL 7031- Grey	
Approximate weight (kg)	: 13.3	

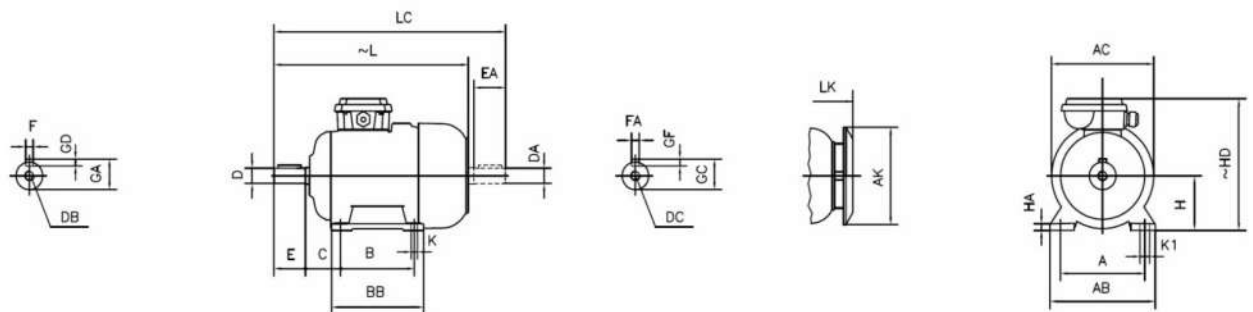

DIMENSIONS

FOOT MOUNTED MOTORS - B3, B6, B7, B8 B15, V5, V6

H	HD ~	HA	A	AB	AC \varnothing	AK \varnothing	K	K1	B	BB	L ~	LC	LK ~	C	E EA	DB DC	D \varnothing DA \varnothing	GA GC	FXGD FAXGF
90	23	12	140	180	176	150	10	15	100	130	308	363	338	56	50	M8	24	27	8X7

contact:

Mob:00201022621584/00201092425789

Email:info@andalos-trading.com

website:www.andalos-trading.com

Egypt-Giza-of October City

Lelat Alqader-Almaged Center