

# MD 80 4b

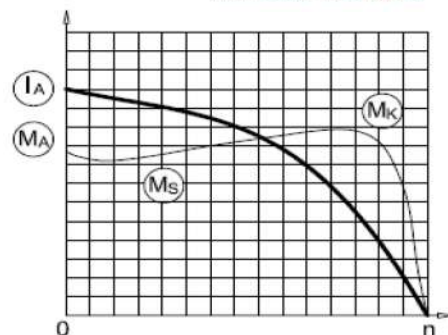

1-Phase 230 V 50 Hz

- Duty Type : S1
- Degree of protection : IP 55 ( TEFC )
- Insulation class : F ( 155 °C )
- Temp rise : Class B ( 80K )
- Mounting Design : B3



## ELECTRICAL DESIGN

- Rated output (kW) : 0.75
- Speed (rpm) : 1405
- Rated current (A) : 4.6
- Torque – Mn (Nm) : 5.1
- Permanent Capacitor 400V (µF) : 30
- Cos φ : 0.98
- Efficiency % : 72.0
- Moment of inertia J (kgm)<sup>2</sup> : 0.00123
- Locked rotor Current – Ia (A) : 16.1
- Ia / In : 3.5
- Locked rotor Torque – Ma (Nm) : 2.81
- Ma / Mn : 0.55
- Breakdown Torque – Mk (Nm) : 9.2
- Mk / Mn : 1.8

## MECHANICAL DESIGN

- Frame : Aluminium
- End shields : Aluminium
- Cooling fan : Plastic
- Terminal box : Plastic
- Cable gland : Pg 16
- No of cable glands : 1

### Bearing Arrangement

- Standard design : 6204 ZZ (Drive End) / 6204 ZZ (Non Drive End)
- Paint : RAL 7031- Grey
- Approximate weight (kg) : 10.3

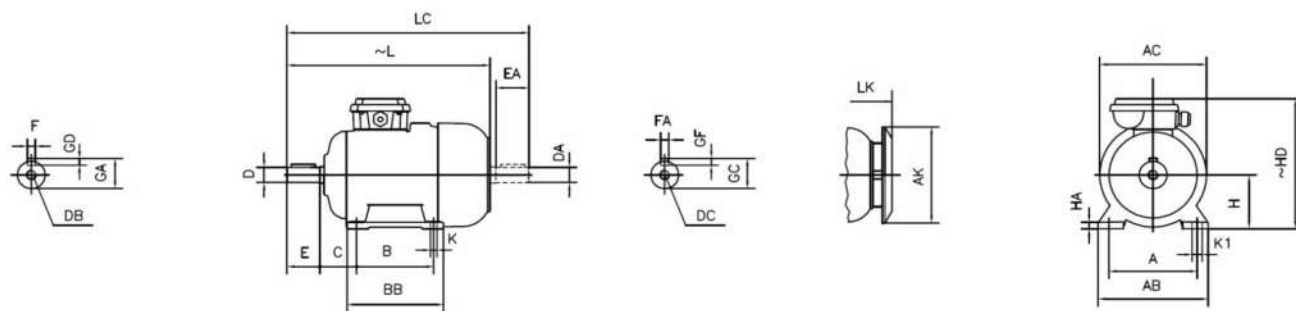

## DIMENSIONS

### FOOT MOUNTED MOTORS - B3, B6, B7, B8 B15, V5, V6

H	HD	HA	A	AB	AC Ø	AK Ø	K	K1	B	BB	L	LC	LK	C	E	DB	DØ	GA	FXGD
	~										~		-		EA	DC	DAØ	GC	FAXGF
80	212	10	125	160	156	150	10	15	100	125	278	323	308	50	40	M6	19	21.5	6X6

contact:

Mob:00201022621584/00201092425789

Email:info@andalos-trading.com

website:www.andalos-trading.com

Egypt-Giza-of October City

Lelat Alqader-Almaged Center