

# MD 80 4a

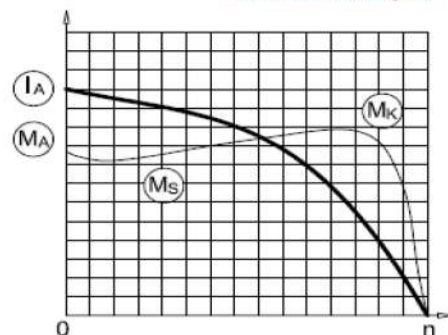

1-Phase 230 V 50 Hz

- Duty Type : S1
- Degree of protection : IP 55 ( TEFC )
- Insulation class : F ( 155 °C )
- Temp rise : Class B ( 80K )
- Mounting Design : B3



## ELECTRICAL DESIGN

- Rated output (kW) : 0.55
- Speed (rpm) : 1410
- Rated current (A) : 3.3
- Torque – Mn (Nm) : 3.73
- Permanent Capacitor 400V (µF) : 20
- Cos φ : 0.97
- Efficiency % : 75.0
- Moment of inertia J (kgm)<sup>2</sup> : 0.00092

- Locked rotor Current – Ia (A) : 11.22  
Ia / In : 3.4
- Locked rotor Torque – Ma (Nm) : 1.90  
Ma / Mn : 0.51
- Breakdown Torque – Mk (Nm) : 6.3  
Mk / Mn : 1.7

## MECHANICAL DESIGN

- Frame : Aluminium
- End shields : Aluminium
- Cooling fan : Plastic
- Terminal box : Plastic
- Cable gland : Pg 16
- No of cable glands : 1

### Bearing Arrangement

- Standard design : 6204 ZZ (Drive End) / 6204 ZZ (Non Drive End)
- Paint : RAL 7031- Grey
- Approximate weight (kg) : 8.7

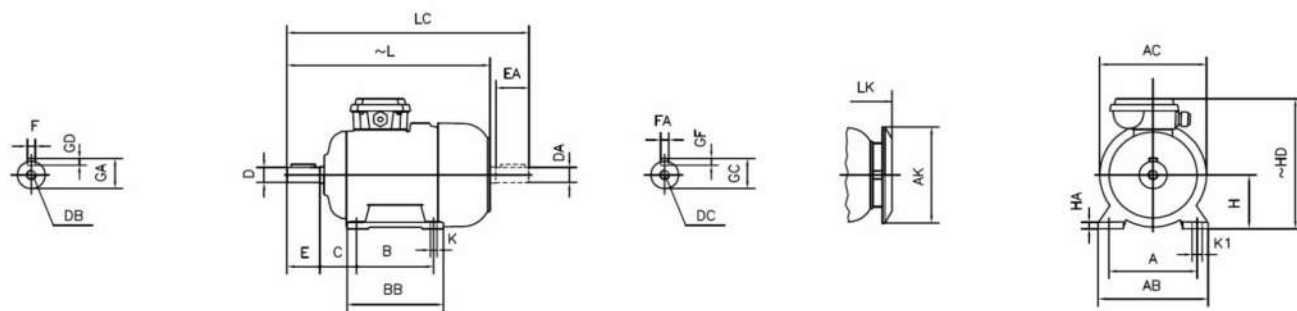

## DIMENSIONS

### FOOT MOUNTED MOTORS - B3, B6, B7, B8 B15, V5, V6

H	HD	HA	A	AB	AC Ø	AK Ø	K	K1	B	BB	L	LC	LK	C	E	DB	DØ	GA	FXGD
~	~	~	~	~	~	~	~	~	~	~	~	~	~	~	EA	DC	DAØ	GC	FAXGF
80	212	10	125	160	156	150	10	15	100	125	278	323	308	50	40	M6	19	21.5	6X6

contact:

Mob:00201022621584/00201092425789

Email:info@andalos-trading.com

website:www.andalos-trading.com

Egypt-Giza-of October City

Lelat Alqader-Almaged Center