

MD 71 4a

GAMAK

شركة الأندلس التجارية
Al Andalos Trading Co

1-Phase 230 V 50 Hz

Duty Type : S1
 Degree of protection : IP 55 (TEFC)
 Insulation class : F (155 °C)
 Temp rise : Class B (80K)
 Mounting Design : B3

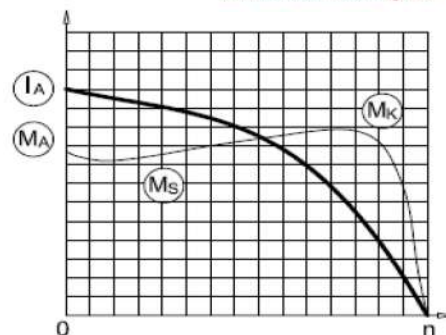

ELECTRICAL DESIGN

Rated output (kW) : 0.25

Speed (rpm) : 1425

Rated current (A) : 1.8

Torque – Mn (Nm) : 1.68

Permanent Capacitor 400V (μF) : 10

Cos φ : 0.93

Efficiency % : 65.0

Moment of inertia J (kgm)² : 0.00048

Locked rotor Current – Ia (A) : 5.76

Ia / In : 3.2

Locked rotor Torque – Ma (Nm) : 1.2

Ma / Mn : 0.73

Breakdown Torque – Mk (Nm) : 3.5

Mk / Mn : 2.1

MECHANICAL DESIGN

Frame : Aluminium
 End shields : Aluminium
 Cooling fan : Plastic
 Terminal box : Plastic
 Cable gland : Pg 16
 No of cable glands : 1

Bearing Arrangement

Standard design

Paint

Approximate weight (kg) : 6.1

Drive End

Non Drive End

6202 ZZ

6202 ZZ

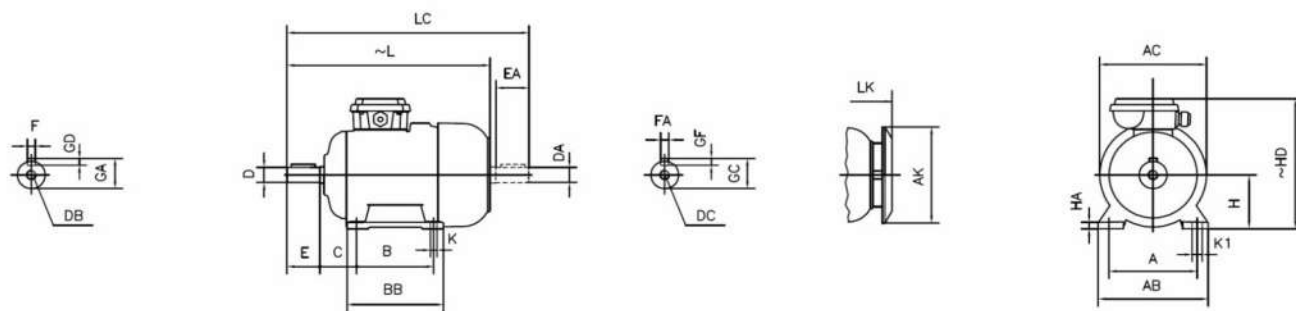
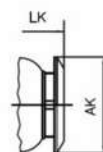

DIMENSIONS

FOOT MOUNTED MOTORS - B3, B6, B7, B8 B15, V5, V6

H	HD	HA	A	AB	AC Ø	AK Ø	K	K1	B	BB	L	LC	LK	C	E	DB	DØ	GA	FXGD
	~										~		~		EA	DC	DAØ	GC	FAXGF
71	196	10	112	140	138	116	7	11	90	108	247	282	277	45	30	M5	14	16	5X5

contact:

Mob:00201022621584/00201092425789

Email:info@andalos-trading.com

website:www.andalos-trading.com

Egypt-Giza-of October City

Lelat Alqader-Almaged Center