

MD 63 4b

GAMAK

شركة الأندلس التجارية
Al Andalos Trading Co

1-Phase 230 V 50 Hz

Duty Type : S1
 Degree of protection : IP 55 (TEFC)
 Insulation class : F (155 °C)
 Temp rise : Class B (80K)
 Mounting Design : B3

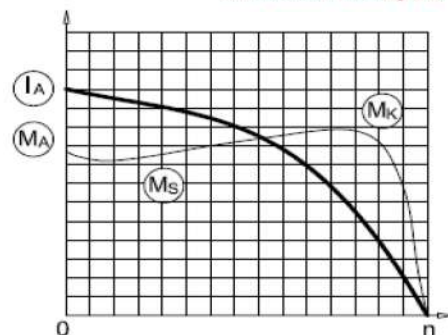

ELECTRICAL DESIGN

Rated output (kW) : 0.18

Speed (rpm) : 1390

Rated current (A) : 1.5

Torque – Mn (Nm) : 1.24

Permanent Capacitor 400V (μF) : 10

Cos φ : 0.93

Efficiency % : 56.0

Moment of inertia J (kgm)² : 0.00023

Locked rotor Current – Ia (A) : 3.45

Ia / In : 2.3

Locked rotor Torque – Ma (Nm) : 1.0

Ma / Mn : 0.84

Breakdown Torque – Mk (Nm) : 2.2

Mk / Mn : 1.8

MECHANICAL DESIGN

Frame : Aluminium
 End shields : Aluminium
 Cooling fan : Plastic
 Terminal box : Plastic
 Cable gland : Pg 11
 No of cable glands : 1

Bearing Arrangement

Standard design

Paint

Approximate weight (kg) : 4.6

Drive End

Non Drive End

6201 ZZ

6201 ZZ

: RAL 7031- Grey

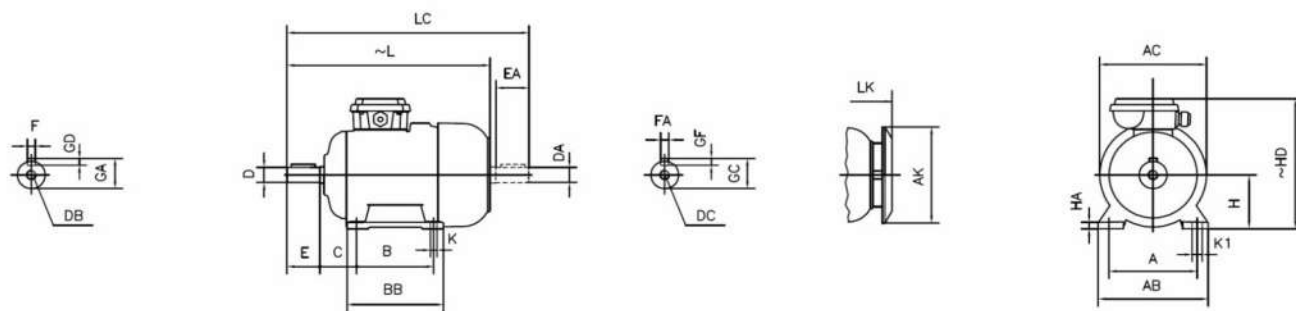

DIMENSIONS

FOOT MOUNTED MOTORS - B3, B6, B7, B8 B15, V5, V6

| H | HD | HA | A | AB | AC Ø | AK Ø | K | K1 | B | BB | L | LC | LK | C | E | DB | DØ | GA | FXGD |
|----|-----|----|-----|-----|------|------|---|----|----|-----|-----|-----|-----|----|----|----|-----|------|-------|
| ~ | ~ | | | | | | | | | | ~ | | ~ | | EA | DC | DAØ | GC | FAXGF |
| 63 | 189 | 10 | 100 | 125 | 121 | 116 | 7 | 11 | 80 | 103 | 215 | 242 | 245 | 40 | 23 | M4 | 11 | 12.5 | 4X4 |

contact:

Mob:00201022621584/00201092425789

Email:info@andalos-trading.com

website:www.andalos-trading.com

Egypt-Giza-of October City

Lelat Alqader-Almaged Center