

GM 315 S 6

GAMAK

شركة الأندلس التجارية
Al Andalus Trading Co

3-Phase 400 V (Δ) 50 Hz

Duty Type : S1
Degree of protection : IP 55 (TEFC)
Insulation class : F (155 °C)
Temp rise : Class B (80K)
Mounting Design : B3

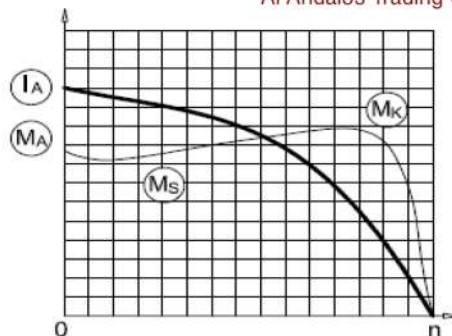

ELECTRICAL DESIGN

Direct On Line

Rated output (kW) : 75	Locked rotor Current – I _a (A) : 980
	I _a / I _n : 7.0
Speed (rpm) : 990	Locked rotor Torque – M _a (Nm) : 1808
	M _a / M _n : 2.5
Rated current (A) : 140	
Y / Δ Starting	
Torque – M _n (Nm) : 723	Locked rotor Current – I _a (A) : 322
	I _a / I _n : 2.3
Cos φ : 0.82	Locked rotor Torque – M _a (Nm) : 578
	M _a / M _n : 0.8
Efficiency % : 93.7 (4/4) 93.7 (3/4) 92.4 (1/2)	Breakdown Torque – M _k (Nm) : 2169
	M _k / M _n : 3.0
Moment of inertia J (kgm) ² : 2.4	

MECHANICAL DESIGN

Frame : Cast Iron
End shields : Cast Iron
Cooling fan : Plastic
Terminal box : Aluminium
Cable gland : Pg 48
No of cable glands : 2

Bearing Arrangement

	Drive End	Non Drive End
Standard design	6318 C3	6318 C3
Reinforced design	NU 318 E	6318 C3
Noise Level (dB-A)	: 72	
Paint	: RAL 7031- Grey	
Approximate weight (kg)	: 727	

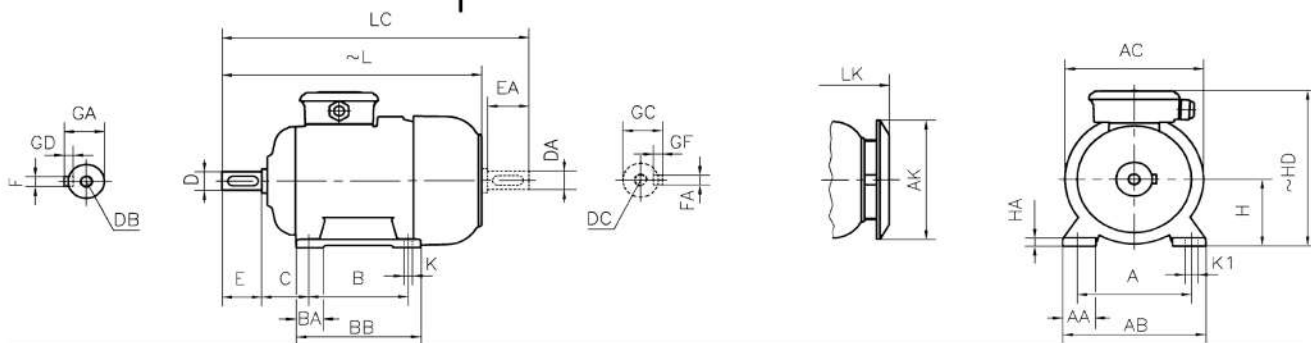

DIMENSIONS

Dimensions of foot mounted motors for mounting arrangement : B3, B6, B7, B8, B15, V5, V6

H	HD	HA	A	AA	AB	ØAC	ØAK	K	K1	B	B'	BA	BA'	BB	L	LC	LK	C	E	DB	ØD	GA	FxGD
~	~																	EA	DC	ØDA	GC	FAXGF	
315	825	50	508	125	620	614	51	28	-	406	-	115	166	550	1150	1330	1227	216	170	M20	85	90	22X14

* Efficiencies are calculated according to indirect method where the additional load losses are determined from exact measurements at different load points.

contact:

Mob:00201022621584/00201092425789

Email:info@andalos-trading.com

website:www.andalos-trading.com

Egypt-Giza-of October City

Lelat Alqader-Almaged Center