

GM 250 M 2

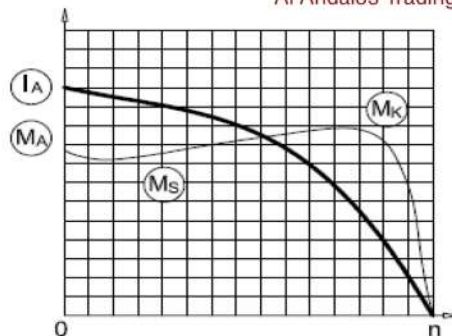

3-Phase 400 V (Δ) 50 Hz

- Duty Type : S1
- Degree of protection : IP 55 (TEFC)
- Insulation class : F (155 °C)
- Temp rise : Class B (80K)
- Mounting Design : B3



ELECTRICAL DESIGN

Direct On Line

Rated output (kW) : 55	Locked rotor Current – Ia (A) : 714
	Ia / In : 7.6
Speed (rpm) : 2980	Locked rotor Torque – Ma (Nm) : 458
	Ma / Mn : 2.6
Rated current (A) : 94	
Torque – Mn (Nm) : 176	
Cos φ : 0.91	
	4/4 3/4 1/2
Efficiency % : 93.2 93.7 92.2	

Y / Δ Starting

Moment of inertia J (kgm) ² : 0.41	Locked rotor Current – Ia (A) : 235
	Ia / In : 2.5
	Locked rotor Torque – Ma (Nm) : 141
	Ma / Mn : 0.8
	Breakdown Torque – Mk (Nm) : 475
	Mk / Mn : 2.7

MECHANICAL DESIGN

- Frame : Cast Iron
- End shields : Cast Iron
- Cooling fan : Plastic
- Terminal box : Aluminium
- Cable gland : Pg 42
- No of cable glands : 2

Bearing Arrangement

	Drive End	Non Drive End
Standard design	6315 ZZ C3	6215 ZZ C3
Reinforced design	NU 315 E	6315 C3
Noise Level (dB-A)	: 76	
Paint	: RAL 7031- Grey	
Approximate weight (kg)	: 445	

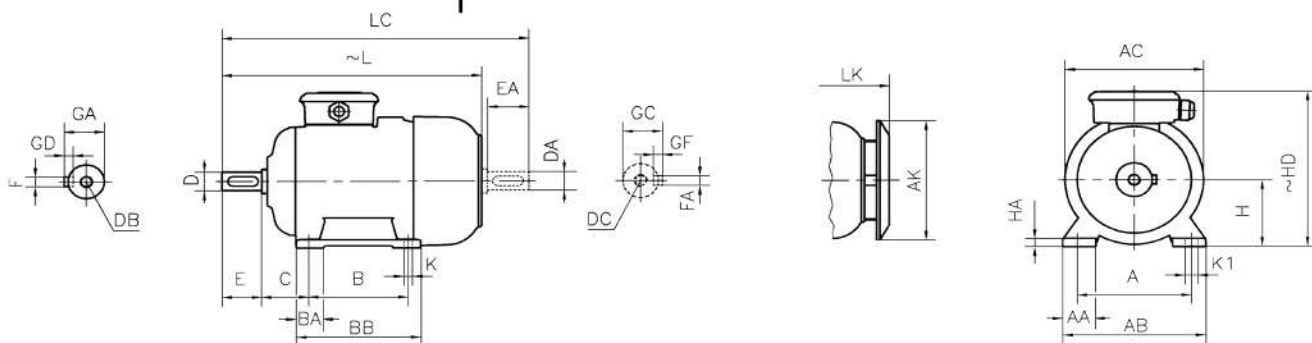

DIMENSIONS

Dimensions of foot mounted motors for mounting arrangement : B3, B6, B7, B8, B15, V5, V6

H	HD	HA	A	AA	AB	ØAC	ØAK	K	K1	B	B'	BA	BA'	BB	L	LC	LK	C	E	EA	DC	ØDA	GA	GC	FxGD	FAXGF
250	572	35	406	80	484	480	440	24	-	349	-	75	-	410	896	1044	952	168	140	M20	60	64	18X11			

* Efficiencies are calculated according to indirect method where the additional load losses are determined from exact measurements at different load points.

contact:

Mob:00201022621584/00201092425789

Email:info@andalos-trading.com

website:www.andalos-trading.com

Egypt-Giza-of October City

Lelat Alqader-Almaged Center