

GM180 M 2

3-Phase 400 V (Δ) 50 Hz

Duty Type : S1

Degree of protection : IP 55 (TEFC)

Insulation class : F (155 °C)

Temp rise : Class B (80K)

Mounting Design : B3

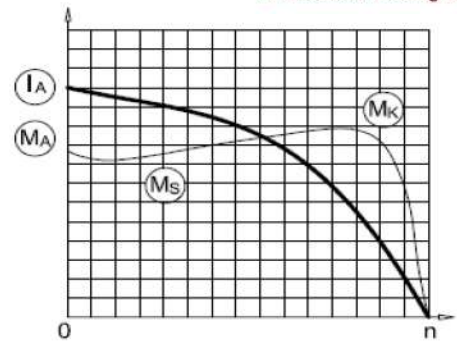

ELECTRICAL DESIGN

Direct On Line

Rated output (kW) : 22

Locked rotor Current – I_a (A) : 314

I_a / I_n : 8.2

Speed (rpm) : 2950

Locked rotor Torque – M_a (Nm) : 214

M_a / M_n : 3.0

Rated current (A) : 38.3

Y / Δ Starting

Torque – M_n (Nm) : 71.2

Locked rotor Current – I_a (A) : 100

I_a / I_n : 2.6

Cos φ : 0.91

Locked rotor Torque – M_a (Nm) : 71

M_a / M_n : 1.0

	4/4	3/4	1/2
Efficiency %	: 91.3	91.3	90.8

Moment of inertia J (kgm)² : 0.066

Breakdown Torque – M_k (Nm) : 249

M_k / M_n : 3.5

MECHANICAL DESIGN

Frame : Cast Iron

End shields : Cast Iron

Cooling fan : Plastic

Terminal box : Plastic

Cable gland : Pg 29

No of cable glands : 2

Bearing Arrangement

Standard design

Drive End

6310 ZZ C3

Non Drive End

6210 ZZ C3

Reinforced design

NU 310 E

6310 C3

Noise Level (dB-A) : 70

Paint : RAL 7031- Grey

Approximate weight (kg) : 158

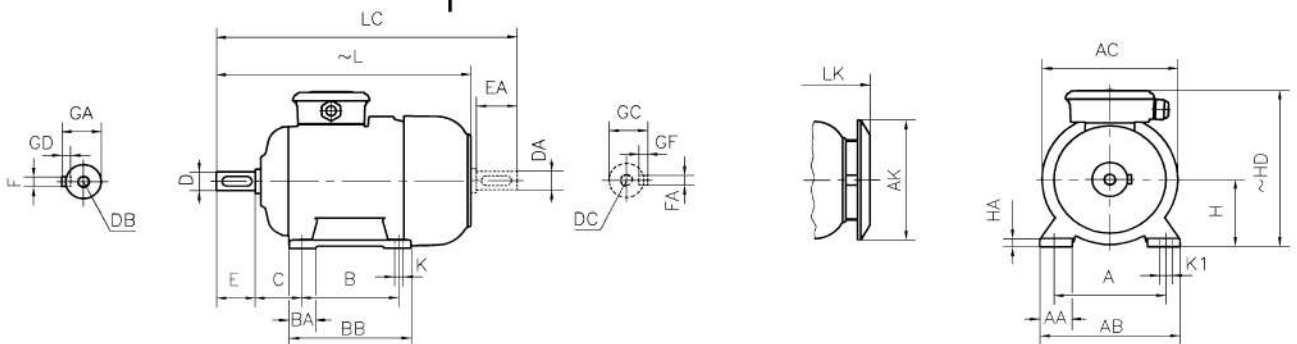

DIMENSIONS

Dimensions of foot mounted motors for mounting arrangement : B3, B6, B7, B8, B15, V5, V6

H	HD	HA	A	AA	AB	∅AC	∅AK	K	K1	B	B'	BA	BA'	BB	L	LC	LK	C	E	EA	DB	DC	∅DA	GA	FxGD	FAXGF
180	421	24	279	68	354	348	303	15	-	241	279	57	85	319	657	773	714	121	110	M16	48	51.5	14X9			

* Efficiencies are calculated according to indirect method where the additional load losses are determined from exact measurements at different load points.

contact:

Mob:00201022621584/00201092425789

Email:info@andalos-trading.com

website:www.andalos-trading.com

Egypt-Giza-of October City

Lelat Alqader-Almaged Center