

GM 280 S 4

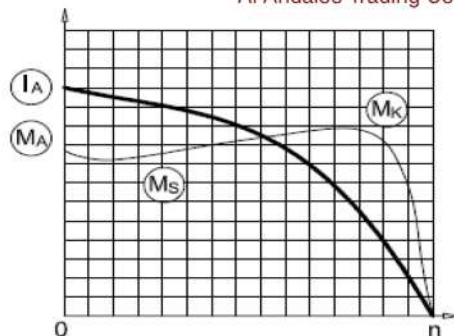

3-Phase 400 V (Δ) 50 Hz

- Duty Type : S1
- Degree of protection : IP 55 (TEFC)
- Insulation class : F (155 °C)
- Temp rise : Class B (80K)
- Mounting Design : B3



ELECTRICAL DESIGN

Direct On Line

Rated output (kW) : 75	Locked rotor Current – Ia (A) : 1051
	Ia / In : 7.9
Speed (rpm) : 1480	Locked rotor Torque – Ma (Nm) : 1258
	Ma / Mn : 2.6
Rated current (A) : 133	
Y / Δ Starting	
Torque – Mn (Nm) : 484	Locked rotor Current – Ia (A) : 333
	Ia / In : 2.5
Cos φ : 0.87	Locked rotor Torque – Ma (Nm) : 387
	Ma / Mn : 0.8
Efficiency % : 94.0 4/4 3/4 1/2	Breakdown Torque – Mk (Nm) : 1355
	Mk / Mn : 2.8
Moment of inertia J (kgm) ² : 0.96	

MECHANICAL DESIGN

- Frame : Cast Iron
- End shields : Cast Iron
- Cooling fan : Plastic
- Terminal box : Aluminium
- Cable gland : Pg 42
- No of cable glands : 2

Bearing Arrangement

	Drive End	Non Drive End
Standard design	6316 ZZ C3	6316 ZZ C3
Reinforced design	NU 316 E	6316 C3
Noise Level (dB-A) : 67		
Paint : RAL 7031- Grey		
Approximate weight (kg) : 550		

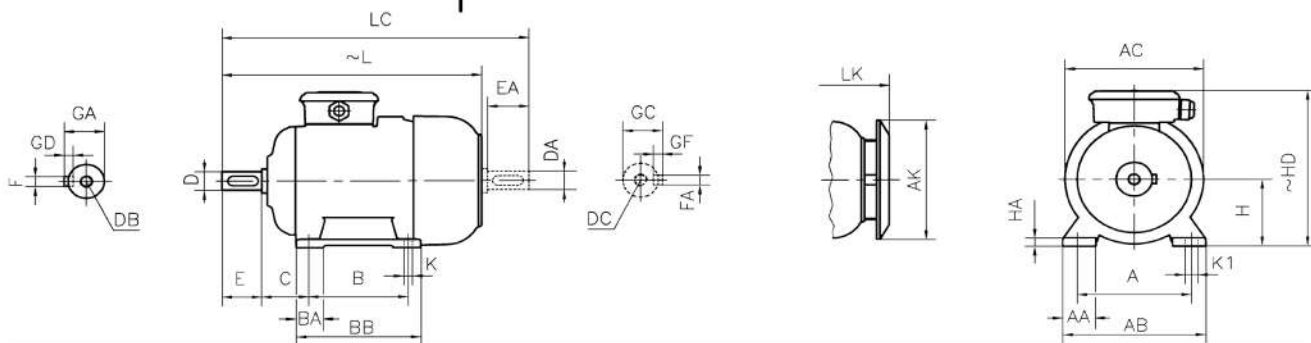

DIMENSIONS

Dimensions of foot mounted motors for mounting arrangement : B3, B6, B7, B8, B15, V5, V6

H	HD	HA	A	AA	AB	ØAC	ØAK	K	K1	B	B'	BA	BA'	BB	L	LC	LK	C	E	DB	ØD	GA	FxGD
~	~																	EA	DC	ØDA	GC	FAXGF	
280	630	40	457	120	550	544	440	24	-	368	-	85	128	474	958	1106	1014	190	140	M20	75	79.5	20X12

* Efficiencies are calculated according to indirect method where the additional load losses are determined from exact measurements at different load points.

contact:

Mob:00201022621584/00201092425789

Email:info@andalos-trading.com

website:www.andalos-trading.com

Egypt-Giza-of October City

Lelat Alqader-Almaged Center