

GM 225 S 4

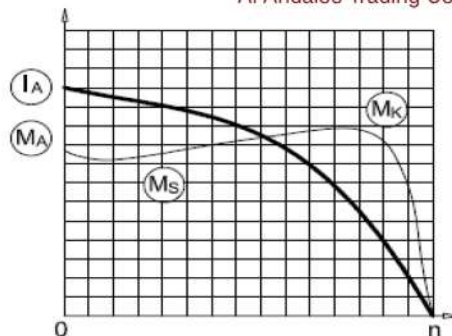

3-Phase 400 V (Δ) 50 Hz

- Duty Type : S1
- Degree of protection : IP 55 (TEFC)
- Insulation class : F (155 °C)
- Temp rise : Class B (80K)
- Mounting Design : B3



ELECTRICAL DESIGN

Direct On Line

Rated output (kW) : 37	Locked rotor Current – Ia (A) : 482
	Ia / In : 7.2
Speed (rpm) : 1470	Locked rotor Torque – Ma (Nm) : 720
	Ma / Mn : 3.0
Rated current (A) : 67	
Y / Δ Starting	
Torque – Mn (Nm) : 240	Locked rotor Current – Ia (A) : 154
	Ia / In : 2.3
Cos φ : 0.86	Locked rotor Torque – Ma (Nm) : 240
	Ma / Mn : 1.0
Efficiency % : 92.7 (4/4) 92.7 (3/4) 92.2 (1/2)	Breakdown Torque – Mk (Nm) : 720
	Mk / Mn : 3.0
Moment of inertia J (kgm) ² : 0.3	

MECHANICAL DESIGN

- Frame : Cast Iron
- End shields : Cast Iron
- Cooling fan : Plastic
- Terminal box : Aluminium
- Cable gland : Pg 36
- No of cable glands : 2

Bearing Arrangement

	Drive End	Non Drive End
Standard design	6313 ZZ C3	6213 ZZ C3
Reinforced design	NU 313 E	6313 C3
Noise Level (dB-A) : 64		
Paint : RAL 7031- Grey		
Approximate weight (kg) : 314		

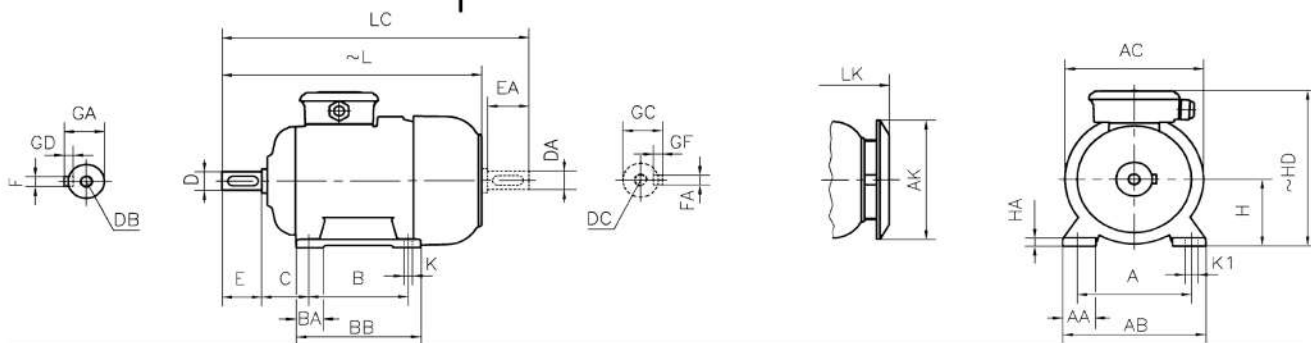

DIMENSIONS

Dimensions of foot mounted motors for mounting arrangement : B3, B6, B7, B8, B15, V5, V6

H	HD	HA	A	AA	AB	ØAC	ØAK	K	K1	B	B'	BA	BA'	BB	L	LC	LK	C	E	EA	DB	DC	ØD	ØDA	GA	GC	FxGD	FAXGF
225	510	30	356	82	438	434	370	19	-	286	311	76	92.5	363	795	943	851	149	140	M20	60	64	18X11					

* Efficiencies are calculated according to indirect method where the additional load losses are determined from exact measurements at different load points.

contact:

Mob:00201022621584/00201092425789

Email:info@andalos-trading.com

website:www.andalos-trading.com

Egypt-Giza-of October City

Lelat Alqader-Almaged Center